

Himel



HDM3 MOLDED CASE CIRCUIT BREAKER

www.himel.com

LOW VOLTAGE DISTRIBUTION

HDM3/3L/3E Series MCCB



Range Presentation

HDM3 is Himel 3 series range of Molded Case Circuit Breakers with fixed thermal magnetic trip unit, providing line protection and motor protection, up to 1600A.

HDM3E is Himel 3 series range of MCCB with electronic type trip unit, providing LSI protection, up to 1600A.

HDM3L is Himel 3 series range of earth leakage MCCB, providing protection against residual current, up to 630A.

Features

Easy Installation and Safe Operation

- ◆ Double-deck cover design assures easy installation and removal of accessories.

High Performance

- ◆ Patented design ensures quick extinguishing of arc.
- ◆ Suitable for wide environment conditions, max. $-40^{\circ}\text{C}\sim+70^{\circ}\text{C}$

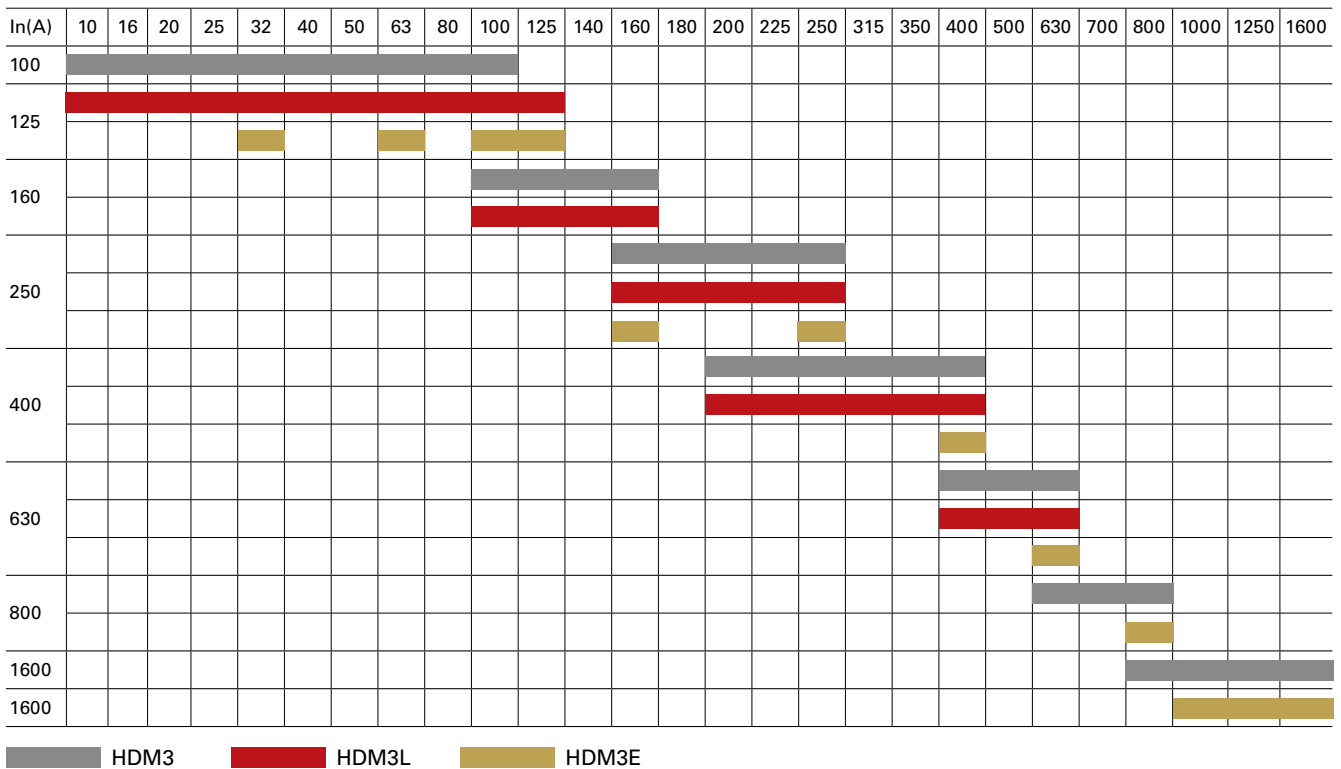

Online Content



HDM3



HDM3E



HDM3L

HDM3/3L/3E Series MCCB



Selection Guide

HDM3 MCCB Selection Code-@40° Products

Range Name	Frame Size	Breaking Capacity (Icu/Ics)	Rated current	Poles	Protection
HDM3	250	L	250	3	3XX
HDM3 MCCB	100: 100A	L: 18/18kA S: 25/18kA	10,16,20,25,32, 40,50,63,100A	3: 3P B*: 4P	2XX2: Mag only motor protection 3XX: Mag-Therma line protection
		T: 30/30kA N: 50/30KA	40,50,63,100A		
	160: 160A	L: 21/21kA S: 35/21kA T: 36/36kA N: 60/36KA	100,125,140,160A		
	250: 250A	L: 21/21kA S: 35/21kA T: 36/36kA N: 60/36KA	160,180,200, 225,250A		
	400: 400A	F: 50/30kA T: 39/39kA N: 70/39kA	200,225,250,315, 350,400A		
	630: 630A	F: 50/30kA T: 39/39kA N: 70/39kA	400,500,630A		
	800: 800A	M: 40/40kA F: 70/40kA	500,630,700,800A		
	1600: 1600A	N: 70/50kA	800,1000,1250,1600A		

Note: for more details of HDM3-1600 characteristics, please see its individual catalogue

HDM3E MCCB Selection Code-@40° Products

Range Name	Frame Size	Breaking Capacity (Icu/Ics)	Rated current	Poles	Protection
HDM3E	250	M	250	3	3XX
HDM3E Electronic type MCCB	125: 125A	M: 50/50kA	32: 32A 63: 63A 100: 100A 125: 125A	3: 3P C*: 4P	3XX: Electronic tripping, line protection
			250: 250A		
	400: 400A		400: 400A		
	630: 630A		630: 630A		
	800: 800A		800: 800A		

LOW VOLTAGE DISTRIBUTION

HDM3/3L/3E Series MCCB



HDM3 MCCB Selection Code-@50° Products

Range name	Frame size	Breaking capacity (Icu/Ics)	Rated current	Poles	Protection	Temperature
HDM3	250	S	250	3	3XX	T
HDM3 MCCB	100: 100A	S: 25/18kA F: 35/26kA N: 50/30kA	10, 16, 20, 25, 32, 40, 50, 63, 80, 100A	3: 3P *A: 4P *B: 4P	2XX2: Mag only motor protection 3XX: Mag-Therma line protection	T: 50
	160: 160A	S: 35/21kA F: 50/30kA N: 60/36kA	100, 125, 140, 160A			
	250: 250A	S: 35/21kA F: 50/30kA N: 60/36kA	100, 125, 140, 160, 180, 200, 225, 250A			
	400: 400A	S: 35/21kA F: 50/30kA N: 70/39kA	200, 225, 250, 315, 350, 400A			
	*800: 800A	F: 50/30kA N: 70/40kA	500,630,700,800A			

HDM3E MCCB selection Code-@50° Products

Range Name	Frame Size	Breaking apacity (Icu/Ics)	Rated current	Poles	Protection	Temperature
HDM3E	250	M	250	3	3XX	T
HDM3E Electronic type MCCB	125: 125A	M: 50/50kA	125: 125A	3: 3P *C: 4P	3XX: Electronic tripping, line protection	T: 50
	250: 250A		250: 250A			
	400: 400A		400: 400A			
	630: 630A		630: 630A			
	800: 800A		800: 800A			

Note:

- *A: The N phase is directly connected with a wire, and without contacts. It's always closed.
- *B: The N phase is equipped with contacts, but without protection. It closes earlier and opens later than the other 3 poles.
- *C: The N phase is equipped with contacts, and with protection. It closes earlier and opens later than the other 3 poles.
- *There is no motor protection for frame current 800A breaker.



HDM3 * HDM3Eoffer is available only in Middle East / North African countries. For more information, contact local Himel Sales.

LOW VOLTAGE DISTRIBUTION

HDM3/3L/3E Series MCCB



HDM3L Earth Leakage MCCB Selection Code-@40° Products

Series Name	Frame Size	Breaking capacity	Rated current	Poles	Trip unit and Protection	Residual current	Time delay
HDM3L	25	F	250	3	3X0	A	1
HDM3L	12: 125A	F: 50/30kA	16,20,25,32,40,50,63, 80,100,125A	3: 3P B*: 4P	3X0: line protection	A: 30/100/300 B: 100/300/500 C: 300/500/1000	0: No delay 1: 0.1/0.2/0.3s 2: 0.4/0.5/1s 3: 0.1/0.3/0.5s
	16: 160A		100,125,140,160A				
	25: 250A		160,180, 200, 225,250 A				
	40: 400A	F: 70/42kA	200,225,250,315, 350,400				
	63: 630A	F: 70/40kA	400,500,630A				

HDM3E 1600A MCCB Selection Code-@40°/50° Products

Series Name	Frame Size	Breaking Capacity	Rated current	Poles	Trip unit	MCH +XF	MX	MN	Controller	Temperature
HDM3E	16	M	16	3	F	5	5	5	L	T
HDM3E	16: 1600A	M: 50/50kA	10: 1000A 12: 1250A 16: 1600A	3: 3P 4: 4P	F: Fixed front connection	5: Without MCH+XF N: AC230V V: AV400V D: DC220V	5: Without Shunt release N: AC230V V: AV400V D: DC220V	5: Without undervoltage release N: AC230V V: AV400V	L: iTR326	T: 50° Default: 40°

Note:

B: The N phase is equipped with contacts, but without protection. It closes earlier and opens later than the other 3 poles.

C: The N phase is equipped with contacts, and with protection. It closes earlier and opens later than the other 3 poles.

"T" is thermal trip calibrated in 50 degree. please contact with HIMEL local office for further information.

LOW VOLTAGE DISTRIBUTION

HDM3/3L/3E Series MCCB



Technical Parameters-@ 40° Products																						
MCCB		HDM3-100				HDM3-160				HDM3-250				HDM3-400			HDM3-630			HDM3-800		
Rated Voltage Ue(V)																						
Rated insulation Voltage Ui(V)		800				800				800				800			800			800		
Rated impulse withstand voltage Uimp(kV)		8				8				8				8			8			8		
Rated frequency(Hz)																						
Rated current In(A)		10-100				100-160				160-250				200-400			400-630			630-800		
Number of poles		3/4																				
Use Category		A																				
Breaking capacity	Breaking Class	L	S	T	N	L	S	T	N	L	S	T	N	F	T	N	F	T	N	M	F	
	Icu(kA) 400/415V AC	18	25	30	50	21	35	36	60	21	35	36	60	50	39	70	50	39	70	40	70	
	Ics(kA) 400/415V AC	18	18	30	30	21	21	36	36	21	21	36	36	30	39	39	30	39	39	40	40	
Mechanical life		20000				20000				20000				10000			10000			5000		
Electrical life AC 400/415V		8000				8000				8000				7500			7500			2500		
Power distribution protection		■				■				■				■			■			■		
Motor protection		■				■				■				■			■			-		
Isolation function		■				■				■				■			■			■		
Certification		TUV, CE				KEMA, CE				KEMA, CE				KEMA, CE			KEMA, CE			KEMA, CE		

Note: for HDM3-100T/N support rated current from 40~100A

Technical Parameters-@ 50° Products																		
Frame current		HDM3-100				HDM3-160				HDM3-250				HDM3-400			HDM3-800	
Rated Voltage Ue(V)		400/415																
Rated insulation Voltage Ui(V)		800				800				800				800			800	
Rated impulse withstand voltage Uimp(kV)		8				8				8				8			8	
Rated frequency(Hz)		50/60																
Rated current In(A)		10-100		40-100		100-160				100-250				200-400			500-800	
Number of poles		3/4																
Use Category		A																
Breaking capacity	Breaking Class	S	F	N	S	F	N	S	F	N	S	F	N	S	F	N		
	Icu(kA) 400/415V AC	25	35	50	35	50	60	35	50	60	35	50	60	35	50	70	50	70
	Ics(kA) 400/415V AC	18	26	30	21	30	36	21	30	36	21	30	36	21	30	39	30	40
Mechanical life		20000				20000				20000				10000			5000	
Electrical life AC 400/415V		8000				8000				8000				7500			2500	
Power distribution protection		■				■				■				■			■	
Motor protection		■				■				■				■			-	
Isolation function		■				■				■				■			■	
Certification		TUV, CE				TUV, CE				TUV, CE				TUV, CE			TUV, CE	

LOW VOLTAGE DISTRIBUTION

HDM3/3L/3E Series MCCB



Technical Parameters-@40°/50°products

Electronic type MCCB		HDM3E-125			HDM3E-250		HDM3E-400		HDM3E-630		HDM3E-800		HDM3E-1600		
Rated Voltage Ue(V)		400/415													
Rated insulation Voltage Ui(V)		800			800		800		800		1000		1000		
Rated impulse withstand voltage Uimp(kV)		8			8		8		8		12		12		
Rated frequency(Hz)		50/60													
Rated current In(A)		32	63	100,125	160,250	400		630		800		1000/1250/1600			
Number of poles		3/4													
Use Category		A			A		B		B		B		B		
Breaking capacity	Breaking Class	M			M		M		M		M		M		
	Icu(kA) 400/415V AC	50			50		50		50		50		50		
	Ics(kA) 400/415V AC	50			50		50		50		50		50		
	Icw(kA) 400/415V AC	0.5(1s)	1(1s)	2.5(1s)	2.5(1s) ¹⁾	5(1s)		8(1s)		10(1s)		42(1s)			
Mechanical life		20000			20000		1000		1000		5000		12500		
Electrical life	AC 400/415V	8000			8000		7500		7500		2500		6000		
Power distribution protection	Electronic trip unit														
Isolation function															
Certification		TUV, CE			TUV, CE		TUV, CE		TUV, CE		TUV, CE		TUV, CE		

Note:

1) Icw will upgrade to 3kA(1s) soon.

LOW VOLTAGE DISTRIBUTION

HDM3/3L/3E Series MCCB



Technical Parameters-@40° Products						
Earth leakage MCCB		HDM3L-125	HDM3L-160	HDM3L-250	HDM3L-400	HDM3L-630
Rated voltage Ue(V)		400/415				
Rated insulation voltage Ui(V)		800	800	800	800	800
Rated impulse withstand voltage Uimp(kV)		8	8	8	8	8
Rated frequency(Hz)		50/60				
Rated current In(A)		16-125	100-160	160-250	200-400	400-630
Number of poles		3/4				
Use category		A				
Breaking capacity	Breaking class	F	F	F	F	F
	Icu(kA) 400/415V AC	50	50	50	70	70
	Ics(kA) 400/415V AC	30	30	30	42	40
	Icw(kA) 400/415V AC	25% Icu				
Mechanical life		20000	20000	20000	10000	10000
Electrical life	AC 400/415V	8000	8000	8000	7500	7500
Power distribution protection	Electronic trip unit					
Isolation function						
Leakage protection						
Rated residual operating current I _{Δn} mA (three rating adjustable)	Non-delay type	30, 100, 300	30, 100, 300	30, 100, 300	100, 300, 500	100, 300, 500
		100, 300, 500	100, 300, 500	100, 300, 500	300, 500, 1000	300, 500, 1000
	Delay type	100, 300, 500	100, 300, 500	100, 300, 500	100, 300, 500	100, 300, 500
		100, 300, 500	100, 300, 500	100, 300, 500	300, 500, 1000	300, 500, 1000
Rated residual non-tripping current I _{Δno} (mA)		50% I _{Δn}				
Non-delay type: breaking time (s)		≤ 0.2				
Fixed delay: 2I _{Δn} limit non-actuating time (s)		0.1/0.2/0.3/0.4/0.5/1	0.1/0.2/0.3/0.4/0.5/1	0.1/0.2/0.3/0.4/0.5/1	0.1/0.2/0.3/0.4/0.5/1	-
Delay adjustable type: 2I _{Δn} limit non-actuating time (s)	0.1/0.2/0.3	0.1/0.2/0.3	0.1/0.2/0.3	0.1/0.2/0.3	0.1/0.2/0.3	0/0.2/0.5
	0.4/0.5/1	0.4/0.5/1	0.4/0.5/1	0.4/0.5/1	0.4/0.5/1	-
Certification		CE	CE	CE	CE	CE

HDM3/3L/3E Series MCCB



Front Overview

HDM3 100-800

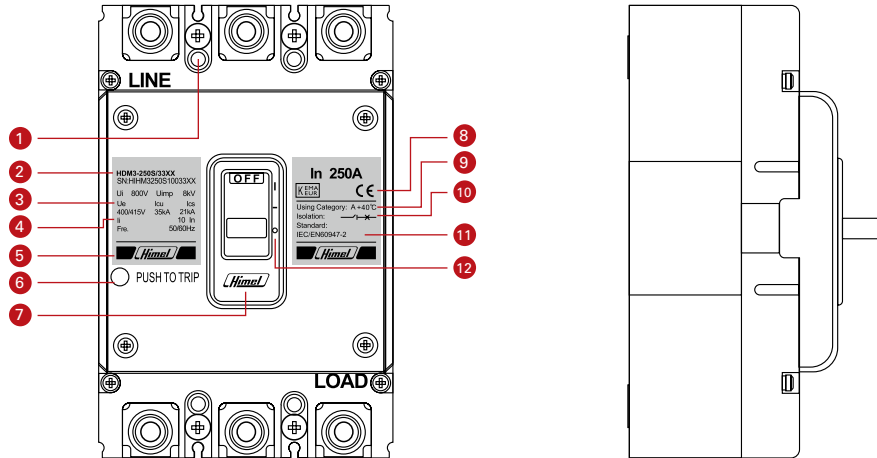

1	Mounting hole	6	Test button	11	Complied standard
2	Product name	7	Brand trademark	12	Closing, tripping and opening
3	Technical parameters	8	Certification mark		
4	Breaking capacity	9	Use category		
5	Brand name	10	Breaker with isolating function		

HDM3E 125-800

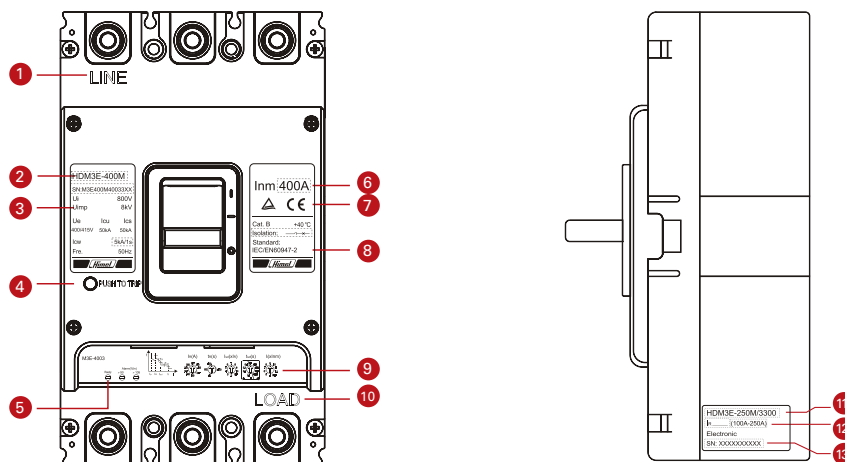

1	Inlet line	6	Frame Current inm	11	Product type
2	Product type	7	Certificate Mark	12	Overload delay time setting current
3	Technical Parameters	8	Standard	13	Reference code
4	Tripping button	9	Parameter adjust knob		
5	Alarm light	10	Outlet line		

HDM3/3L/3E Series MCCB



HDM3L 125-630

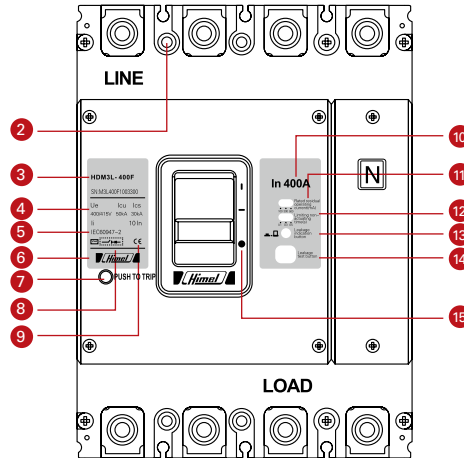
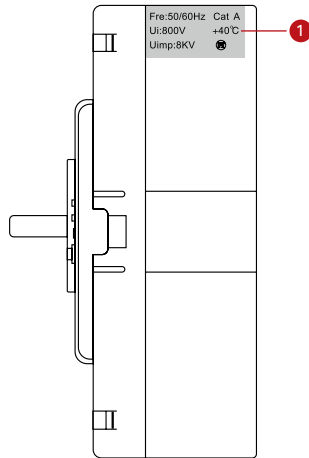

1	Technical parameters	6	Manufacturer trademark	11	Rated residual operating current
2	Mounting hole	7	Trip button	12	Limiting non-actuating time
3	Product model	8	Breaker with isolating function	13	Leakage indication button
4	Breaking capacity	9	Certification mark	14	Leakage test button
5	Conformance standard	10	Rated current	15	Closing, tripping and opening

HDM3/3L/3E Series MCCB



HDM3E 1600

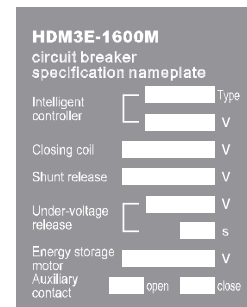
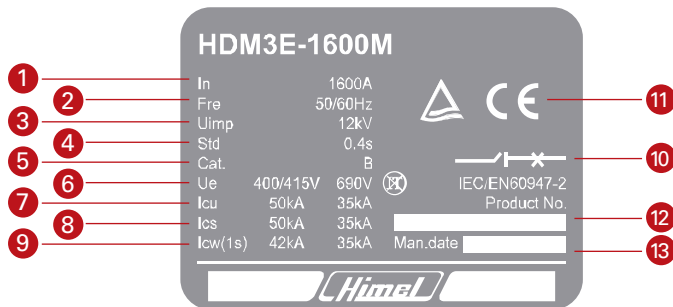
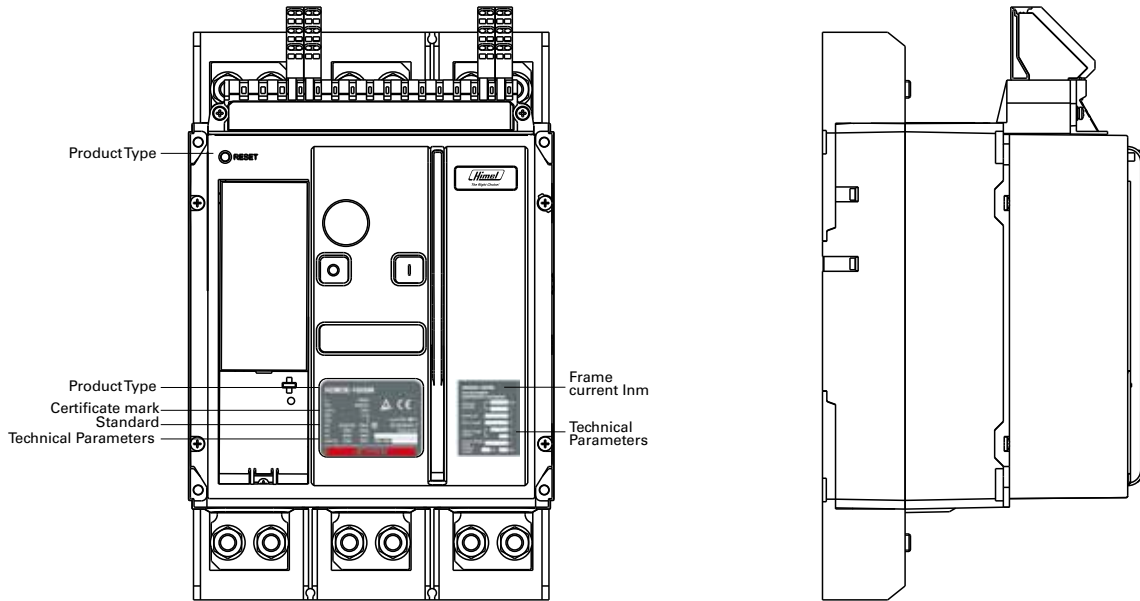

1	Rated current	6	Rated voltage	11	Certification and standard
2	Rated frequency	7	Breaking capacity of limit short circuit	12	Ex-factory code
3	Rated impulse withstand voltage	8	Breaking capacity of operation short circuit	13	Production date
4	Maximum short circuit delay time	9	Rated short time withstand current		
5	Application category	10	Applicability		

Operating Conditions

Pollution Degree

HDM3 products operate in the environment (industrial environment) with pollution class 3 defined in IEC/EN 60947-1 and IEC/EN 60947-2 standards.

Wet and heat resistance

Dry and cold
Dry and heat
Wet and heat

Environment temperature

- HDM3 series can work for a long time under normal environment and operating temperature between -5°C and 50°C.
- Refer to the temperature derating factor table or contact us if the operating ambient temperature exceeds 40°C (motor protection exceeds 60°C).
- Storage temperature ranges between -20°C and 70°C.

Altitude

- Altitude at normal installation site does not exceed 2000m.
- If the altitude exceeds 2000m, the changes in the dielectric strength and the air temperature drop must be considered. Refer to the altitude derating factor table or contact us.

Humidity

The following conditions must be met during normal operation:

- The relative humidity of atmosphere does not exceed 50% if the ambient air temperature is +40°C. The product can be used at a high relative humidity if the temperature is low.
- The monthly average relative humidity at the wettest month is 90%.
- The impact of the condensation generated on the product surface on the product property shall be considered.

Reliable contact indication with isolating function

HDM3 moulded case circuit breaker complies with the isolation defined in IEC standard 60947-2

- The isolated location corresponds to O (OFF)
 - The operating handle can indicate "OFF" only when the contact is really open
 - The rotation handle or electric operating mechanism will not change the reliability of the contact indication system.
- Through the test, the isolating function must guarantee:
- Mechanical reliability of contact indication system
 - No leakage current
 - There is a certain overvoltage resistance capacity between the input and output terminals.

Protection class

- IP protection class of circuit breaker body: IP20
- Circuit breaker installed in the switch cabinet:
circuit breaker with a toggle handle: IP40
circuit breaker with an electric operating mechanism: IP40

HDM3/3L/3E Series MCCB



Safety Distance

HDM3/3L/HDM3E-125~800

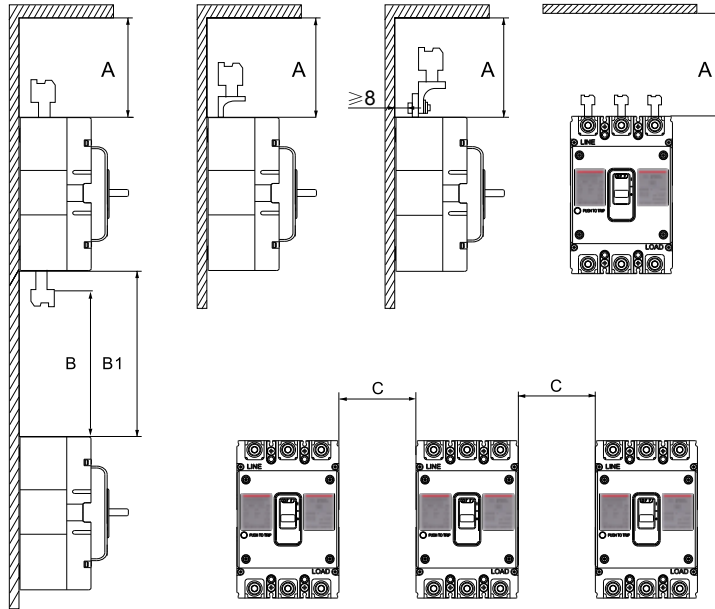

Product type	A(mm)	B(mm)	B1(mm)	C(mm)
HDM3-100/160/250	60	60	Bare cable length+B	30
HDM3E-125/250				
HDM3L-125/160/250				
HDM3-400/630/800	110	110	Bare cable length+B	70
HDM3E-400/630/800				
HDM3L-400/630				

HDM3E-1600

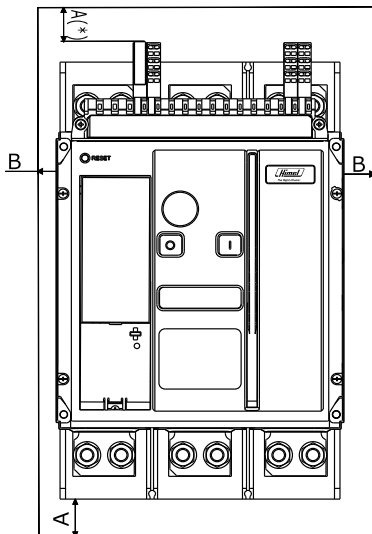

	Insulation part	Metal part	Charged part
A	0	120	180
B	0	10	60

Note: X and Y are front plane symmetric axis.

(*) 50mm safety distance for removing arcing cover, 20mm safety distance for removing terminals.

F : Reference point.

HDM3/3L/3E Series MCCB



Installation Type

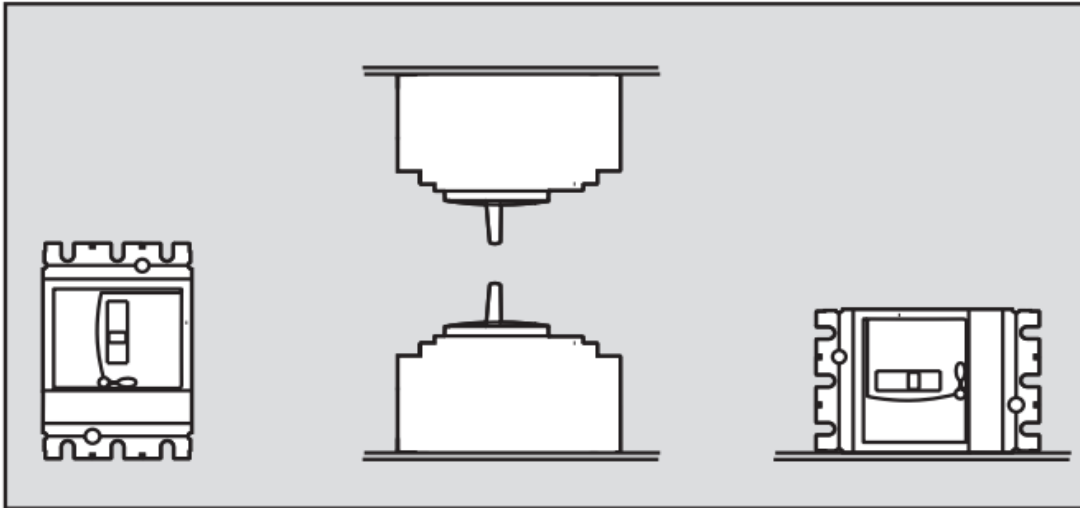

Deratig of Temperature

Product type	Ambient temperature (40°C product)				
	40	45	50	55	60
HDM3-100L/S/T/N	1	0.96	0.89	0.83	0.75
HDM3-160/250 HDM3L-160/250	1	0.92	0.85	0.79	0.71
HDM3-400/630 HDM3L-400	1	0.94	0.87	0.81	0.73
HDM3-800 HDM3L-630	1	0.95	0.88	0.82	0.74

Product type	Ambient temperature (40°C product)				
	40	45	50	55	70
HDM3E-125	1	1	1	Inm=80A	Inm=63A
HDM3E-250	1	1	1	Inm=200A	Inm=160A
HDM3E-400	1	1	1	Inm=315A	Inm=250A
HDM3E-630	1	1	1	Inm=500A	Inm=400A
HDM3E-800	1	1	1	Inm=560A	Inm=500A
HDM3E-1600	1	1	Inm=1500A	Inm=1250A	Inm=1000A

Note: Max IR is smaller than Inm

HDM3/3L/3E Series MCCB



Derating of Altitude

Altitude	2000m	3000m	4000m	5000m
Insulation voltage U_i (V)	800	728	664	616
U_{imp} (kV)	8	7	6.5	6
Power frequency withstand voltage (V)	3000	2500	2100	1800
Rated heat value at 40°C (A)	I_n	$0.94I_n$	$0.88I_n$	$0.85I_n$

Power Consumption for Three Poles

Product type	Rated current (A)	Front connection (W)	Rear connection (W)	Plug-in connection (W)	Withdrawable connection (W)
HDM3-100L/S	100	26	29	29	-
HDM3-100T/N	100	40	50	50	-
HDM3-160	160	60	87	87	-
HDM3-250	250	63	90	90	-
HDM3-400	400	115	120	125	128
HDM3-630	630	180	190	200	205
HDM3-800	800	200	230	290	300

Product type	Rated current (A)	Front connection (W)	Rear connection (W)	Plug-in connection (W)	Withdrawable connection (W)
HDM3E-125	125	60	87	87	-
HDM3E-250	250	63	90	90	-
HDM3E-400	400	115	120	125	128
HDM3E-630	630	180	190	200	250
HDM3E-800	800	200	230	290	300
HDM3E-1600	1600	250	-	-	-

Trip Units

Thermal and magnetic trip unit HDM3/HDM3L 63-800

Protection

The circuit breaker equipped with TM thermomagnetic release is mainly for protection of the cable, which is on the power distribution system for transformer power supply.

Overload protection: thermal protection I_r (Fixed)

The overload protection function provides inverse time limit curve on the basis of bimetal. If the limit is exceeded, the deformation of the bimetal can lead in the tripping of the circuit breaker operating mechanism.

Test No.	I/I _n	Conventional time	Breaker status	Initial status
1	1.05	> 1h(I _n ≤63A) > 2h(I _n > 63A)	Non-tripping	Cold status
2	1.3	≤1h(I _n ≤63A) ≤2h(I _n > 63A)	Tripping	Immediately after test 1

Short circuit protection: magnetic protection I_i(Fixed)

Magnetic protection achieves short circuit protection through a magnetic trip device. The circuit breaker will trip instantaneously. I_i set at 10I_n.

Test No.	I	Breaker status	Conventional time
1	80%I _i	Non-tripping	≥0.2s
2	120%I _i	Tripping	≤0.2s

Magnetic

The circuit breaker equipped with magnetic release is mainly for protection of the motor.

Short circuit protection: magnetic protection I_i(Fixed)

Magnetic protection achieves short circuit protection through a magnetic trip device. The circuit breaker will trip instantaneously. I_i set at 12I_n

Test No.	I	Breaker status	Conventional time
1	80%I _i	Non-tripping	≥0.2s
2	120%I _i	Tripping	≤0.2s

Electronic trip unit HDM3E-125~800

3P controller

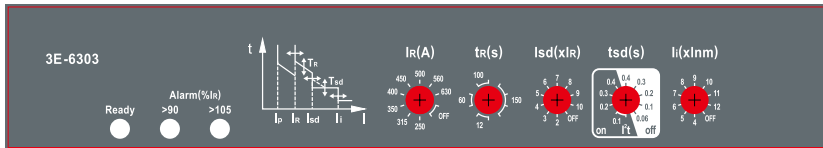

4P controller

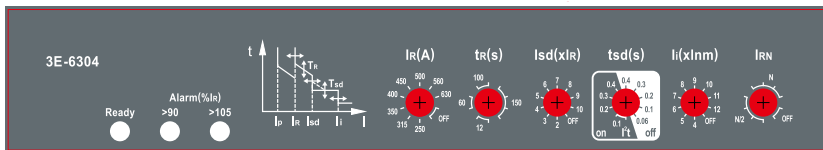

Controller Description

- I_R : Overload long delay setting current
- I_{sd} : Short-circuit short delay setting current
- I_i : Short-circuit instantaneous setting current
- Ready : Run light
- $> 90\%I_R$: pre-alarm light
- : LSI three section protection curve

- t_R : Overload long delay setting time
- t_{sd} : Short-circuit short delay setting time
- I_{RN} : Short-circuit short delay setting time
- Alarm : Alarm light
- $>105\%I_R$: Overload alarm light

1) Overload long delay setting current I_R

Adjust I_R knob, can select the different current value of HDM3E, to satisfy the rated operating current requirement of different electrical wiring.

Following sketch is the adjust knob: I_R

Product Type	Overload long delay current protection feature setting value I_R (A)	Remark
HDM3E-125 32A	14,16,18,20,25,28,30,32	OFF means close overload long delay protection
HDM3E-125 63A	32,36,40,45,50,56,60,63	OFF means close overload long delay protection
HDM3E-125 100A	40,45,50,63,70,80,90,100	OFF means close overload long delay protection
HDM3E-125 125A	50,63,70,80,90,100,110,125	OFF means close overload long delay protection
HDM3E-250 160A	80,90,100,110,125,140,150,160	OFF means close overload long delay protection
HDM3E-250 250A	100,125,140,160,180,200,225,250	OFF means close overload long delay protection
HDM3E-400 400A	160,200,225,250,300,315,350,400	OFF means close overload long delay protection
HDM3E-630 630A	250,315,350,400,450,500,560,630	OFF means close overload long delay protection
HDM3E-800 800A	350,400,450,500,560,630,700,800	OFF means close overload long delay protection

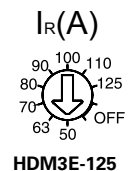

HDM3/3L/3E Series MCCB



2) Overload long delay setting time t_R

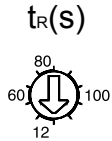

HDM3E-125/250

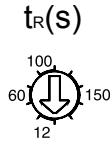

HDM3E-400/630/800

t_R Action time @ $2I_R$

The following table is action value corresponding for different overload long delay time when the fault current is $1.5I_R$, $2I_R$, $6I_R$

Actual Current	Action time to different knob t_R (s), accuracy $\pm 10\%$, $t = (2I_R / I)^2 \times t_R$				
	12	60	80	100	150
$1.5I_R$	21.3	106.7	142.2	177.8	266.7
$2I_R$	12	60	80	100	150
$6I_R$	1.33	6.67	8.89	11.11	16.67

As example of HDM3E-400 product, how to set the overload long delay setting current and time. If select I_R 300, T_r is 60.

When overload current is $1.5I_R$ (450A), the range of overload action time is $106.7 \pm 10.67s$. When overlaod current is $2I_R$ (600A), the range of overload action time is $60 \pm 6s$.

When overlaod current is $6I_R$ (1800A), the range of overload action time is $6.67 \pm 0.667s$.

It is the same theroy for the other section knob value.

3) Short-circuit short delay setting current I_{sd}

$I_{sd} (\times I_R)$

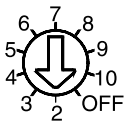

Selection knob of short-circuit short delay setting current I_{sd} : 2、 3、 4、 5、 6、 7、 8、 9、 10、 OFF

Setting current I_{sd} vaule is the tap position of xI_R (can adjust by overload tripping current setting value) OFF means close the action option of short-circuit short delay time .

4) Short-circuit short delay setting time t_{sd}

$t_{sd}(s)$

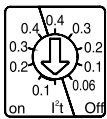

Short time delay protection is used to ensure the selectivity coordination with the downstream circuit breakers. There are I^2t ON (inverse time limit) and I^2t OFF (fixed time limit) two type. The following table is the value of short delay tripping

time t_{sd} : $t = (8I_{sd}/I)^2 \times t_{sd}$

t_{sd} action time@ $8I_{sd}$

I^2t ON @ $8I_{sd}$	Setting time $t_{sd}(s)$	-	0.1	0.2	0.3	0.4
	$I > 8I_R$ delay time(s)	-	0.1	0.2	0.3	0.4
I^2t OFF	Setting time $t_{sd}(s)$	0.06	0.1	0.2	0.3	0.4
	Return time(ms)	20	80	140	230	350
	Max break time(ms)	100	140	220	320	500

As example of HDM3E-250, how can we set inverse time limit setting time of short-circuit short delay.

If I_R is selected 200, I_{sd} is selected on $2xI_R$ position, t_{sd} is selected on I^2t ON, t_{sd} is selected on 0.2 position When short-circuit current is $2xI_R$ (400A), the short-circuit short time delay action time is 3.2s.

Note: when $I_R = OFF$, short-circuit short delay action current I_{sd} is matching to I_{nm} .

5) Short-circuit Instantaneous setting current $I_i (\times I_{nm})$

$I_i (\times I_{nm})$

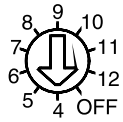

Short-circuit Instantaneous setting current $I_i (\times I_{nm})$	HDM3E-125/250 /400/630/800	(4,5,6,7,8,9,10,11,12,OFF) $\times I_{nm}$
---	-------------------------------	--

6) Neutral phase setting protection $I_{RN} (\times I_R / I_{nm})$

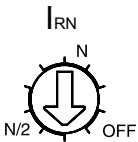

Setting current I_{RN} value selected knob is $\times I_R / I_{nm}$. Neutral phase protection is special for 4 poles circuit breakers. There are three type:

- OFF: Close neutral phase protection function, used for power distribution system without neutral protection situation
- N/2: Used for neutral phase wiring conductor cross-section equal to half of phase line of power distribution system long time delay, short time delay are also equal to the 1/2 of setting value of phase line protection in this status
- N: Used for neutral phase wiring conductor cross-section equal to phase line of power distribution system long time delay, short time delay instantaneous setting value are also equal to setting value of phase line protection in this status.

Note: When I_R is OFF, controller will automatically use the basic reference (I_{nm}) current as the neutral phase protection

7) Controller working status indicate

Following table is status of Run indicate light(Ready), Alarm indicate light(Alarm):

Run status	Ready	Alarm		Remark
	Green	Yellow	Red	
Normal	Blink	Extinguish	Extinguish	$I < 0.9 I_R$
Pre-alarm	Blink	Blink	Extinguish	$0.9 I_R \leq I \leq I_R$
Tripping	Extinguish	Extinguish	Extinguish	$1.05 I_R < I$

Note:

- 1, I is current of main circuit, I_R is overload long time delay setting current value.
- 2, When yellow light blink, that means intelligent controller had worker on overload long time delay, setting parameters on the controller board is unavailable in this process.

HDM3/3L/3E Series MCCB



Electronic trip unit HDM3E-1600

Controller Function and Characteristics

3E-1600(Basic type)

Indicate and button description

- | | |
|---|--|
| 1 Alarm indicate light | 9 Short time delay Isd |
| 2 Long time delay tripping indicate | 10 Short time delay tripping delay tsd |
| 3 Short time delay or Instantaneous tripping indicate | 11 Earthing fault tripping Ig |
| 4 Earthing tripping indicate | 12 Earthing fault tripping delay tg |
| 5 High level protection | 13 Lock position |
| 6 Reset button | 14 Testing button |
| 7 Long time delay current setting I_R | 15 Instantaneous tripping current |
| 8 Long time delay tripping delay t_R | 16 Testing connection port |

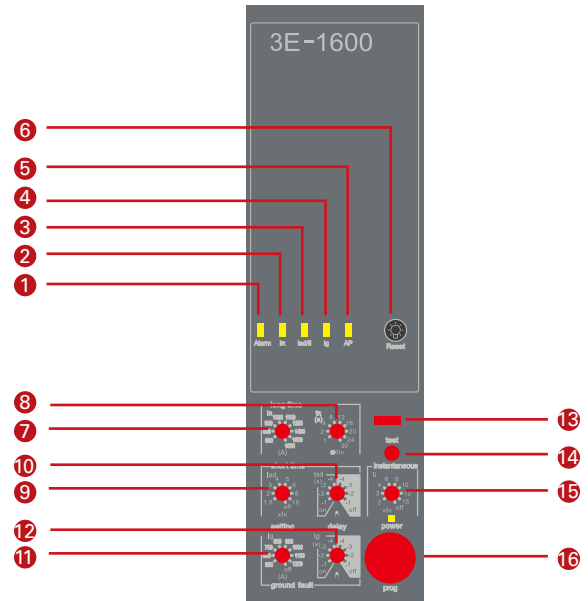

Electronic unit HDM3E-1600

Protection Function	Long-time delay protection I_R Short-time delay protection Isd Instantaneous protection li Earthing protection Ig
Miscellaneous Function	Pre-alarm Self-diagnosis function

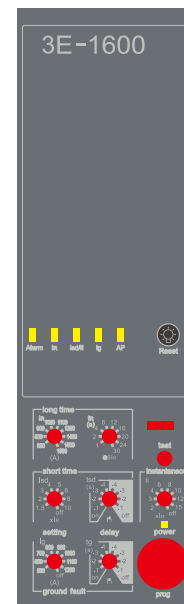

3E-1600

Intelligent controller protection characteristics

Intelligent controller protection characteristics have inverse time limit and fixed time limit. When fault current exceed the setting value of inverse time limit, controller will work on the delay time protection according to fixed time limit setting. Inverse time limit curve conform to characteristics curve $I^2 t$

1) Overload long time dealy protection characteristics I_r

Overload long time delay protection action threshold vaule
 $< 1.05 I_{r}; > 2h$ inaction
 $\geq 1.2 I_{r}$;action delay
 I_r current setting range:630A,800A,900A,1000A,1100A,1250A,1400A,1500A,1600A

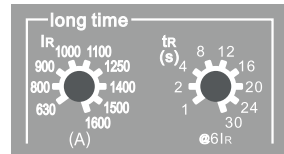

Inverse time limit action characteristics		$I^2 t: t=(6/N)^2 * t_R$							
Setting current	Action time s								
1.5 I _r	16s	32s	64s	128s	192s	256s	320s	384s	480s
2 I _r	9s	18s	36s	72s	108s	144s	180s	216s	270s
6 I _r	1s	2s	4s	8s	12s	16s	20s	24s	30s

Notes: N---- Fault current divide by setting current I/I_r
 t-----Fault action delay time
 t_r ----Long time delay setting value
 Action time permissible error±10%

2) Short-circuit short time dealy protection characteristics I_{sd}

Short-circuit short time delay protection action threshold vaule
 $< 0.9 I_{sd}$ inaction
 $\geq 1.1 I_{sd}$; action delay
 I_{sd} current setting range:1.5 I_r ,2 I_r ,3 I_r ,4 I_r ,5 I_r ,6 I_r ,8 I_r ,10 I_r ,OFF

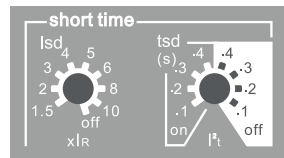

Setting current	Action time					
I _{sd} < I ≤ 8I _r	Inverse time limit	Action character	$I^2 t = (8I_{sd}/t)^2 t_{sd}$			
		Delay time s	0.1, 0.2, 0.3, 0.4			
I ≥ 1.1I _{sd}	Fixed time limit, returned time is minimum value	Setting time s	0.1	0.2	0.3	0.4
		Min s	0.08	0.14	0.23	0.35
		Max s	0.14	0.2	0.32	0.5

Notes: I_{sd} ---- Short time delay current setting value
 I ---- Fault current value
 I_r ---- Long delay time current setting value
 t ---- Fault action delay time
 t_{sd} ---- Short time delay inverse time limit setting value
 Action time permissible error ± 20%

(The off of time means I² t is inverse time limit closed, this state is fixed inverse limit; use current konb is off, that means short time delay protection function is closed.)

HDM3/3L/3E Series MCCB



3) Instantaneous protection characteristics li

Short-circuit instantaneous protection action threshold value

< 0.85 li inaction

> 1.15 li action

Instantaneous action current setting value 2In, 3In, 4In, 6In, 8In, 10In, 12In, 15In, OFF

Note: Action time permissible error ≤ 50ms.

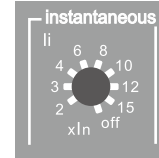

4) Earthing fault protection action characteristics lg

Earthing fault protection action threshold value

< 0.9 lg; inaction

≥ 1.1 lg; action delay

Ig current setting range: 500A, 600A, 700A, 800A, 900A, 1000A, 1100A, 1200A, OFF

tg(s)	Inverse time limit	Action Character				
		$t = \frac{(I_f)^2}{I^2} \times t_g$				
Fixed time limit, returned time is minimum value	Settingtime (s)	0.1	0.2	0.3	0.4	
	Settingtime (s)	0.1	0.2	0.3	0.4	
	Min (s)	0.08	0.14	0.23	0.35	
	Max (s)	0.14	0.2	0.32	0.5	

Notes: IJ Earthing protection setting value, IJ =1200A

I Fault current value

T Fault action delay time

tg Earthing inverse time limit setting value

Inverse time limit action permissible error ± 20%

(The off means is inverse time limit closed, this state is fixed time limit. Use current knob is off, that means earthing protection function is closed.)

5) Intelligent controller setting value

	Long time delay		Short time delay		Instantaneous	Earthing fault		Thermal memory
Tripping curve	I _R	t _R	I _{sd}	t _s	li	I _g	t _g	
I _{2t}	1600A	30s	6In	0.2s	10In	1100A	0.4s	20min

LOW VOLTAGE DISTRIBUTION

HDM3/3L/3E Series MCCB



Controller Function and Characteristics

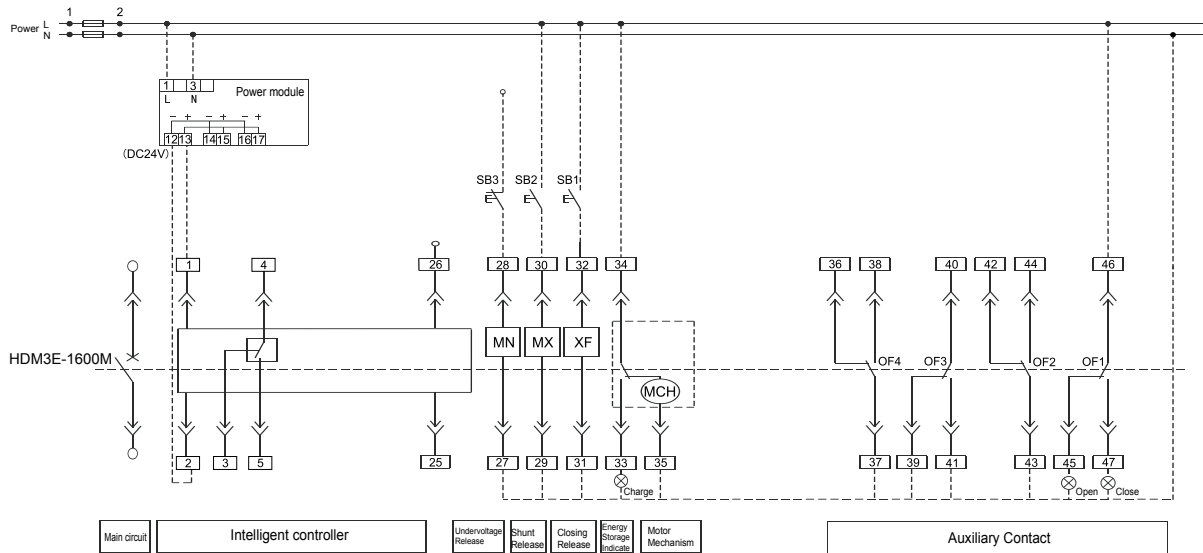

Controller Introduction:

Power: Power supply

1#,2# is auxiliary power DC24V , 1# is connect to positive terminal, and 2# is connect to negative terminal.

SWT: Fault tripping contact outlet(alarm contact)

3#,4#,5# are a set of transfer contact, and 4# is the common terminal, AC 400V,5A.

Note 1: 27#, 28# is under-voltage release terminal, connect from main circuit.

Note 2: controller must connect power supply, when voltage power is AC220~400V, use iAPU334 power module; when power is DC220/110V, use iAPU332D power module.

Note 3: HDM3E-1600M standard equipped with 4 NO 4 NC close contact.

Note 4: MN, MX, XF,MCH are also optional accessories.

Note 5: Terminal 35# can not only be connected to power supply directly, achieve pre-storage energy automatically, but also can connect to the power supply by tandem connection with normal open button (achieve pre-storage energy manually). The dotted line part need connect by user.

Button by users:

SB1—closing button

SB2—opening button

SB3—emergency cut-off button

Components:

MN— Under-voltage release

MX— Shunt release

XF— Closing release

MCH— Motor mechanism

OF1-OF4—Auxiliary contacts

- Function introduction
- In direct current, supply auxiliary power supply for intelligent controller

HDM3/3L/3E Series MCCB



Earth leakage protection

Residual current circuit breakers are used to provide protection against leakage current which may cause insulation failure , electric shock to equipment and human body. HDM3L ELCB also can provide protection against over load & short circuit.

- ① Rated Current In
- ② Rated residual operating current I Δ n
- ③ IBreaking time
- ④ Indicator button
- ⑤ Test button



Time-delayed type
(Time adjustable)

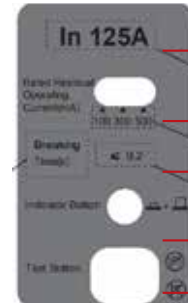

Non-time-delayed
type

Rated residual operating current I Δ n:

Adjustable I Δ n can select different value to provide protection against leakage current in different condition.

Product type	Time-delayed type	Non-time-delayed type
	Rated residual operating current I Δ n/mA	
HDM3L-125	100/300/500	30/100/300; 100/300/500
HDM3L-160	100/300/500	30/100/300; 100/300/500
HDM3L-250	100/300/500	30/100/300; 100/300/500
HDM3L-400	100/300/500; 300/500/1000	100/300/500;300/500/1000
HDM3L-630	100/300/500; 300/500/1000	100/300/500;300/500/1000

Limiting non-actuating time

Maximum delay during which a residual current higher than the rated residual non-operating current can be applied to the ELCB without bringing it actually to operate. The limiting non-actuating time is defined at 2 IΔn.

Product type	Time-delayed type
	Limiting non-actuating time(s) @2 IΔn
HDM3L-125	0.1/0.2/0.3; 0.4/0.5/1
HDM3L-160	0.1/0.2/0.3; 0.4/0.5/1
HDM3L-250	0.1/0.2/0.3; 0.4/0.5/1
HDM3L-400	0.1/0.2/0.3; 0.4/0.5/1
HDM3L-630	0.1/0.3/0.5

For Non-time-delayed type ELCB, break times ≤ 0.2S

Indicator button

- ① Status means that breaker is tripped by leakage current.
- ② Status means that if breaker is tripped, it is caused by overload or short circuit

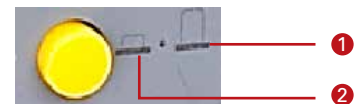

Test button

It is used to simulate the passing through the detecting device of a residual current, in order to allow periodic testing of the ability of ELCB to operate.

Attention:

Wiring power input from load side is not permitted.

HDM3/3L/3E Series MCCB



Accessories HDM3/HDM3L/HDM3E 125-800

Overview of Accessories

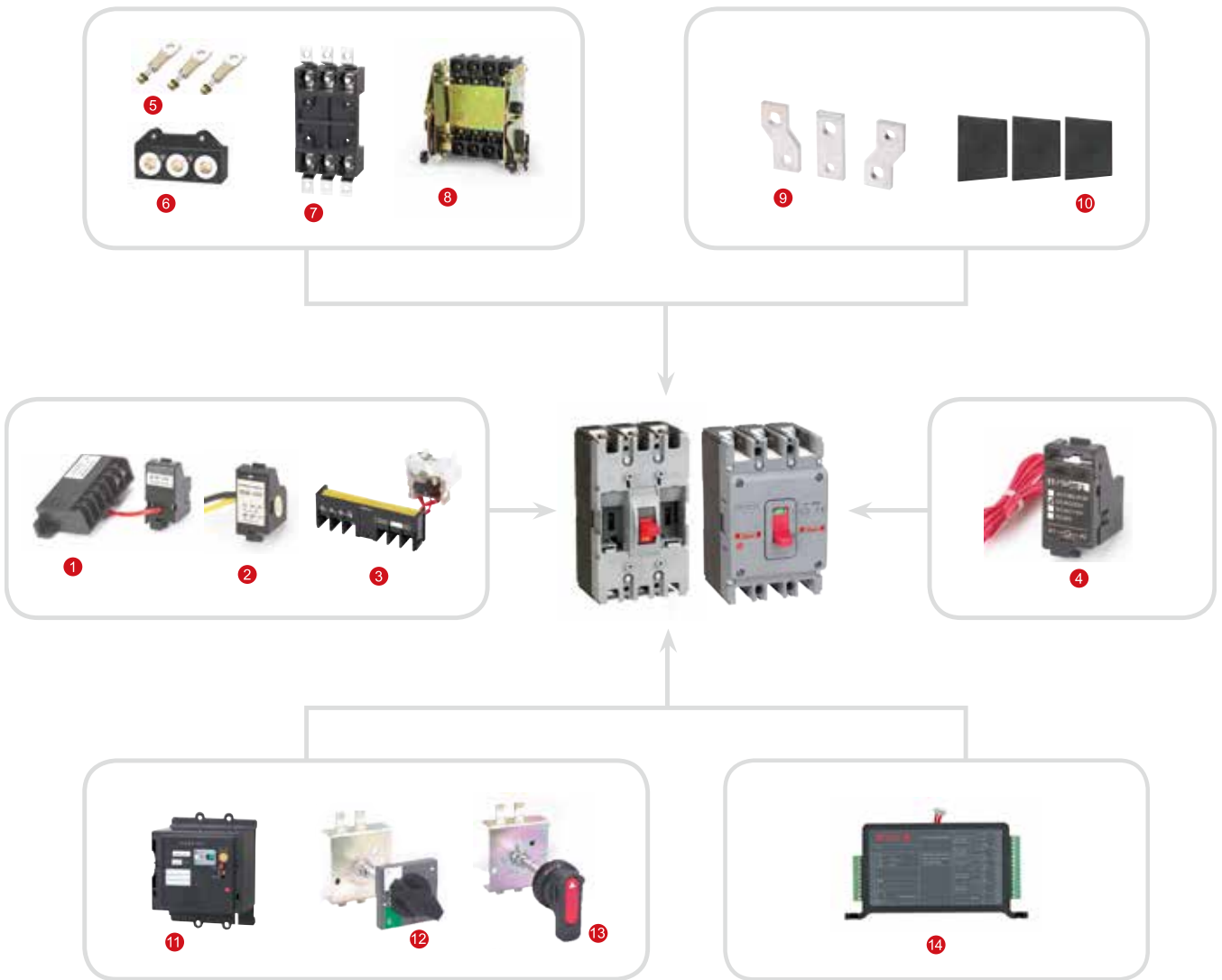

1	Undervoltage release	6	Plug-in rear connection	11	Electric operating mechanism
2	Auxiliary contact	7	Plug-in front connection	12	Square handle operating mechanism
3	Alarm contact	8	Withdrawable connection	13	Round handle operating mechanism
4	Shunt release	9	Extension terminal	14	Modbus RTU (for HDM3E 125-800)
5	Fixed rear connection	10	Interphase barriers		

*Note: For more information about the accessories, please download MCCB catalogue from Himel website.

HDM3/3L/3E Series MCCB



Internal Accessories

Accessories installation

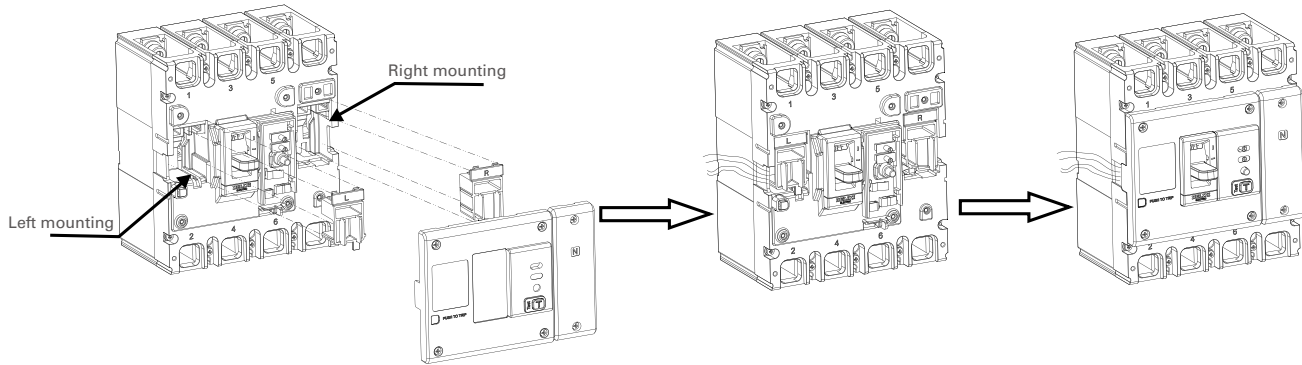

Take the top cover down, and put accessories into left and right chamber of the middle cover and compress it. and install the top cover, tighten the screws. An accessory can be installed in the left or right position, including shunt release, undervoltage release, auxiliary contact, alarm and auxiliary contact.

Auxiliary contact

An accessory connected in the auxiliary circuit of the switching device to indicate the circuit breaker status of ON, OFF or TRIP

Electrical wiring diagram

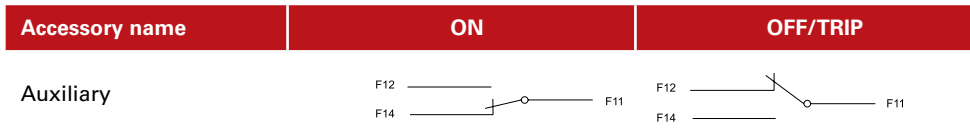

Electrical parameters			
Conventional Thermal Current		3A	
Use category		AC 15	DC 13
Working electricity 50Hz	AC 400V	0.3A	/
	DC 220V	/	0.15A

Alarm contact

An accessory used to indicate the circuit breaker status of ON, OFF or TRIP. When the alarm contact indicates that the circuit breaker is at Trip status, there are the following five possibilities

- Overload or short circuit fault
- Manual test button trip
- Line fault and undervoltage release action
- Residual current fault
- Shunt release action

Electrical wiring diagram

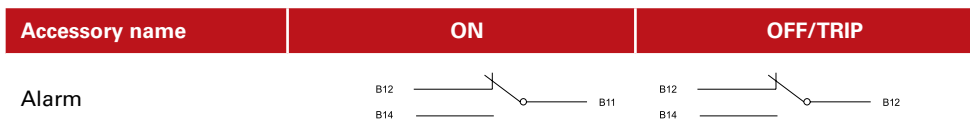

Electrical parameters			
Conventional Thermal Current		3A	
Use category		AC 15	DC 13
Working electricity 50Hz	AC 400V	0.3A	/
	DC 220V	/	0.15A

HDM3/3L/3E Series MCCB



Undervoltage release

- The undervoltage release shall reliably trip the circuit breaker at the voltage between 35% and 70% of the rated operational voltage;
- The undervoltage release shall ensure that the circuit breaker can be switched on at the voltage between 85% and 110% of the rated operational voltage;
- The undervoltage release shall prevent the circuit breaker from switching on when voltage is below 35% of the rated operational voltage

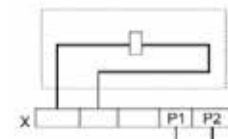

Power input

Electric wiring diagram of undervoltage release

Note: X- terminal block

Note: In the dashed box,

it is the wiring diagram of accessories in the circuitbreaker.

Product type	Undervoltage release power consumption(W)	
	AC400V	AC230V
HDM3-100L/S	4	3.1
HDM3-100T/N HDM3L-125	3.9	3.2
HDM3-160/250 HDM3L-160/250 HDM3E-125/250	4.3	3.3
HDM3-400 HDM3L-400 HDM3E-400	3.6	2.5
HDM3-630 HDM3E-630/800	3.4	2.5
HDM3-800 HDM3L-630	2	1.6

Shunt release

>The shunt release shall reliably trip the circuit breaker at the voltage between 70% and 110% of the rated control power voltage U

>The circuit breaker shall be reset on the site after tripping through the shunt release.

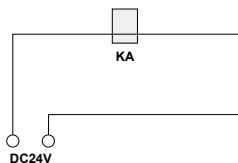

KA: DC24V intermediate relay with the contact current capacity of 1A

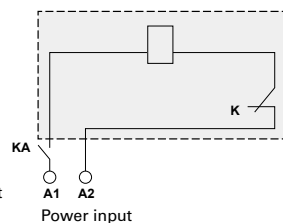

Power input



Product type	Shunt release power loss(W)		
	AC400V	AC230V	DC24V
HDM3-100L/S	91.6	76.1	91.2
HDM3-100T/N HDM3L-125	96.8	73	91.2
HDM3-160/250 HDM3L-160/250 HDM3E-125/250	112	68.6	85.3
HDM3-400 HDM3L-400 HDM3E-400	67	62.3	100
HDM3-630 HDM3E-630/800	68	58.2	100
HDM3-800 HDM3L-630	163	153	120

External accessories

	Fixed front	Fixed rear	Plug-in front	Plug-in rear	Withdrawable
HDM3-100	■	■	■	■	/
HDM3-160	■	■	■	■	/
HDM3-250 HDM3E-125/250	■	■	■	■	/
HDM3-400 HDM3E-400	■	■	/	■	■
HDM3-630 HDM3E-630	■	■	/	■	■
HDM3-800 HDM3E-800	■	■	/	■	■
HDM3E-1600	■	/	/	/	/

Plug-in

The wiring type is divided into plug-in Rear Connection and plug-in Front Connection
The plug-in connection for the products is easy for maintenance and replacement, but plug-in and plug-out cannot be done with the electricity.



Draw out

The drawer-out products can be easily maintained and replaced Visual connection and break-up.



Handle

Handle operating mechanism

The circuit breaker can be operated by the rotation of the handle and the ergonomically designed rotation handle makes the operation of the circuit breaker more flexible.



2 types of rotation handle operating mechanisms:

- > Direct rotation handle (round handle operating mechanism and square handle operating mechanism)
- > Extended rotation handle (round extending handle operating mechanism and square extended handle operating mechanism)

User visualization information/settings:

- > 3 position indications: OFF, ON and TRIP
- > The circuit breaker cannot be switched on when the door is open
- > The door cannot be opened when the circuit breaker is switched on
- > The axial length of the extended handle can be custom made according to the distance from the back of the circuit breaker to the door.



HDM3/3L/3E Series MCCB



Rear connection

Easy to install and connect the products in the rear connection.



Expend terminal

The extension terminal is connected to the standard terminal of the circuit breaker, in order to provide many other wiring schemes in the limited space:

- >Direct extension terminal
- >Extension terminal with inter-electrode distance



The busbar and extension terminal can be connected to the inlet or outlet terminal of the circuit breaker.

Interphase barriers

The interphase barriers can enhance the insulating performances between phase and phases . They can be installed from the product front even though the products had mounted. Interphase barriers will be offered by standard, 3P product(4pcs), 4P product(6pcs).



Motor

- Apply to remote electric connection, disconnection and re-trip of the circuit breaker and the automation control occasions.
- Rated voltage of electric operating mechanism: AC400V;AC230V/DC220V;AC/DC110V;DC24V
- Operating voltage range of electric operating mechanism: 85%-110% Ue

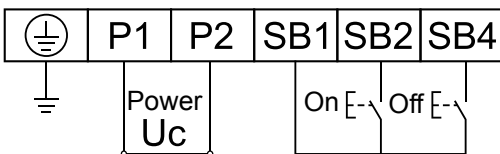

- There are two types of electric operating mechanisms:
 - CD2 General electric operating mechanism for AC and DC(HDM3-63~800)
- CD2 electric operating voltage and tolerance range:
 - CD2:63A-250A:Operating frequency ≤ 180 times/hour and actuation ; time \leq greater than 0.7s
 - CD2:400A-630A:Operating frequency of ≤ 60 times/hour; actuation time ≤ 1 s
- The voltage tolerance range is 184~253VAC/187~242VDC when the rated control power voltage is 230VAC/220VDC.
 - The voltage tolerance range is 320~440VAC when the rated control power voltage is 400VAC.
 - As for different operating forces of the circuit breaker, the switch with relatively small force can be normal.



HDM3/3L/3E Series MCCB

Accessories HDM3E 1600

Overview of Accessories

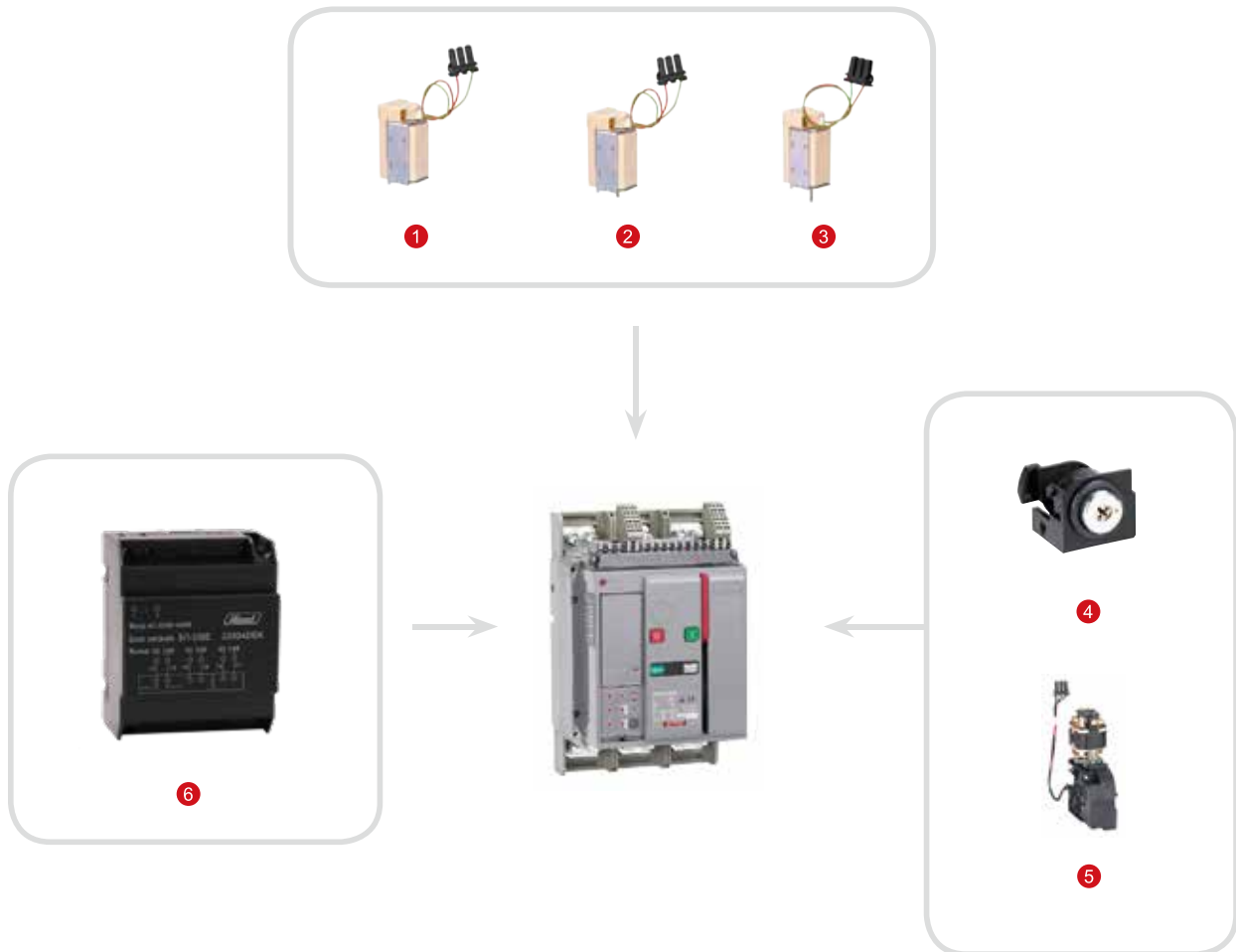

1 Close release

3 Undervoltage release

5 Motor

2 Shunt release

4 Key lock

6 Power Module

HDM3/3L/3E Series MCCB

HDM3E 1600 Accessories install and wiring

Taking down the cover and secondary connection terminal.

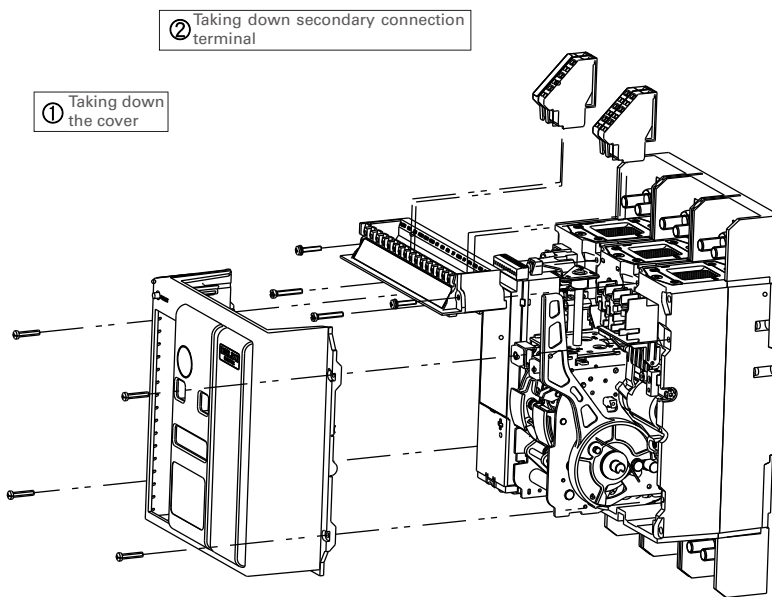

Danger:
Make sure power supply shut down before installation

Installing coil, motor operating mechanism and auxiliary contact

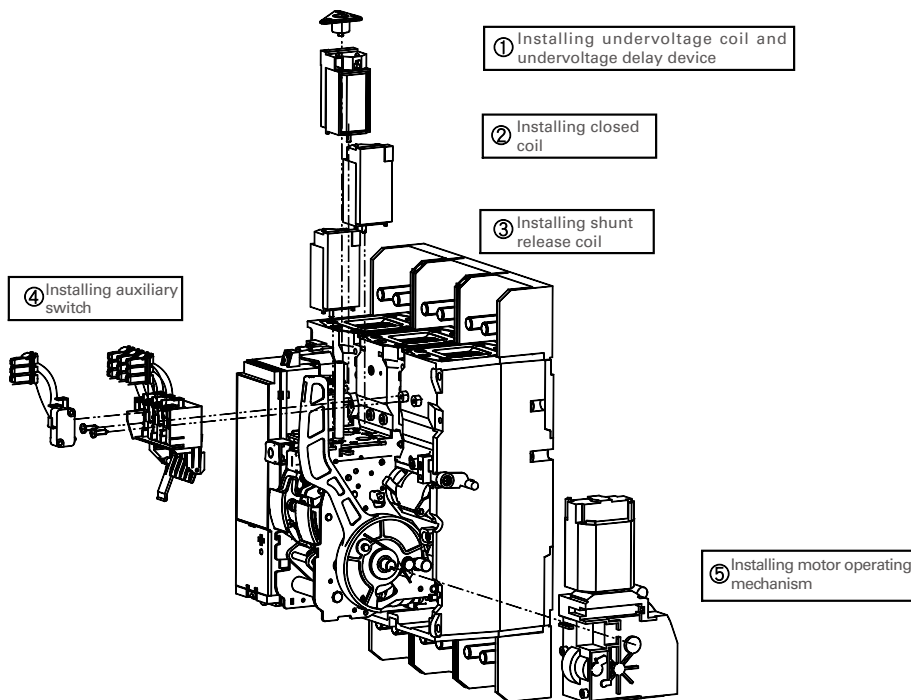

HDM3/3L/3E Series MCCB



Fixing auxiliary terminal

Fixed type
Inserting auxiliary terminal into groove directly

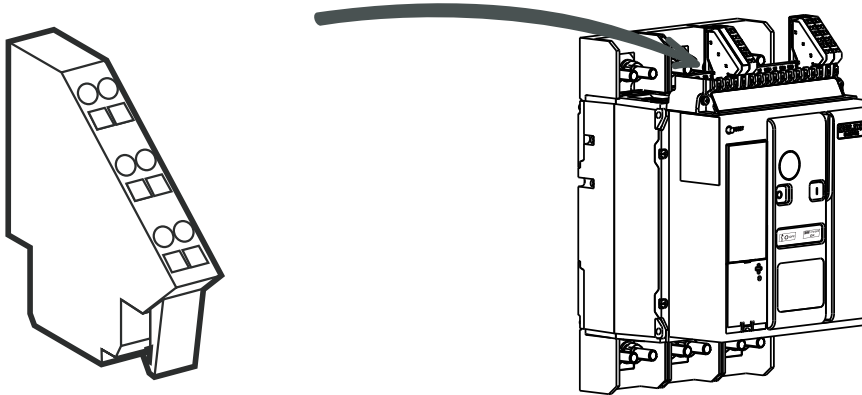

Wiring for auxiliary terminal

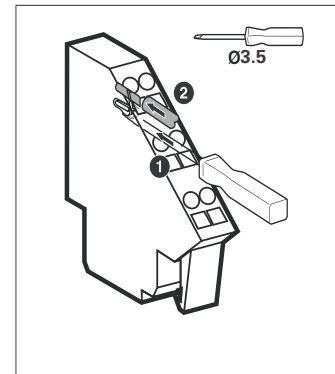
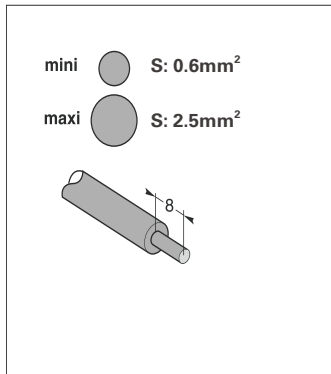

Sectional area of wire
Min 0.6mm²
Max 2.5mm²
The stripper wire needs at least 8mm

- 1 Insert screwdriver into the box and press down
- 2 Meanwhile insert wire into circle
- 3 Release screwdriver, make sure wire connect with auxiliary terminal

Terminal layout

DC24V

Res(SWT2)	UM	ZSI	Pow	SWT	Com	CT	MN	MX	XF	MCH	PF	OF4	OF3	OF2	OF1
	22	13 17	1	5	10	25	27	29	31	35		38	41	44	47
	23	16 19		3	12					33		36	39	42	45
	21 24	14 15	2	4	11	26	28	30	32	34		37	40	43	46
Control Unit							Remote Operating					Auxiliary Switch			

1. Check terminal serial number
2. Inserting same serial number of connection port
3. Pow 1,2 is DC24V power supply port, make sure use with DC 24V from factory. Note:DC24V can be positive and negative connection, do not access directly to 230V power.

HDM3/3L/3E Series MCCB



Undervoltage release

- Function introduction
- The under-voltage release automatically opens a circuit breaker when voltage drops to a value ranging between 35% to 70% of the line voltage. After tripping the circuit breaker cannot be re-closed again when the voltage goes below 35% or until it returns to 85% of line voltage. Under-voltage relay release makes the breaker break in 1s-3s (adjustable)



Accessory parameter	
Rated operational voltage V	AC400V AC230V
Operational voltage	$(0.35-0.7)U_e$
Dependable closing voltage	$(0.85-1.1)U_e$
Unable closing voltage	$\leq 0.35U_e$
Consumption	12VA
Delay time	1s-3s

Shunt release

- Function introduction
- When the breaker is stored and under specified voltage, Shunt release can make the breaker break through long-distance remote control.



Accessory parameter	
Rated operational voltage V	AC230V AC400V DC220V
Operation voltage	$(0.7-1.1)U_s$
Consumption	300VA(AC) 40W(DC)
Breaking time	<30ms

Closing release

- Function introduction
- When the breaker is stored and under specified voltage, Shunt release can make the breaker close through long-distance remote control.

Accessory parameter	
Rated operational voltage V	AC230V AC400V DC220V
Operational voltage	$(0.85-1.1)U_s$
Consumption	300VA(AC) 40W(DC)
Breaking time	<70ms

HDM3/3L/3E Series MCCB



Motor

- When the breaker is open with power supply, MCH can store energy for ACB automatically, thus the breaker can be opened and closed with the operation of MX, MN, XF. It can be manually stored when there is no power.

Accessory parameter	
Rated control power voltage V	AC230V AC400V DC220V
Action voltage	(0.85-1.1)Us
Consumption	150W (maxi.)
Energy storage time	<5s



Power supply

- Function introduction
- In direct current, supply auxiliary power supply for intelligent controller

Accessory parameter		
Model	Input	Output
IAPU334	AC220V~400V	DC24V 0.4A
IAPU332D	DC220V/110V	



HDM3/3L/3E Series MCCB



Accessories Selection Guide



Frame Size	Contact	Auxiliary contact with wire		Auxiliary contact with Terminal		
		Left	Right	Left	Right 3P	Right 4P
HDM3-100L/S	1NC+1NO	HDM3100SOF11K1BL	HDM3100SOF11K1BR	HDM3100SOF21K1BL	HDM3100SOF21K1BR3	HDM3100SOF21K1BR4
HDM3-100T/N HDM3L-125	1NC+1NO	HDM3100FNOF11K1BL	HDM3100FNOF11K1BR	HDM3100FNOF21K1B	HDM3100FOF21K1BR3	HDM3100FOF21K1BR4
HDM3-160/250 HDM3E-125/250 HDM3L-160/250	1NC+1NO	HDM3250OF11K1BL	HDM3250OF11K1BR	HDM3250OF21K1BL	HDM3250OF21K1BR3	HDM3250OF21K1BR4
	2NC+2NO	HDM3E250OF12K2BL	HDM3E250OF12K2BR	HDM3E250OF22K2BL	HDM3E250OF22K2BR3	HDM3E250OF22K2BR4
HDM3-400/630 HDM3E-400/630/800 HDM3L-400	1NC+1NO	HDM3630OF11K1BL	HDM3630OF11K1BR	HDM3630OF21K1BL	HDM3630OF21K1BR3	HDM3630OF21K1BR4
	2NC+2NO	HDM3E630OF12K2BL	HDM3E630OF12K2BR	HDM3E630OF22K2BL	HDM3E630OF22K2BR3	HDM3E630OF22K2BR4
HDM3-800 HDM3L-630	1NC+1NO	HDM3800OF11K1BL	HDM3800OF11K1BR	HDM3800OF21K1BL	HDM3800OF21K1BR3	HDM3800OF21K1BR4

Note: Right side mounted part is not adept with HDM3L MCCB

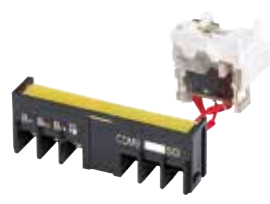

Frame Size	Alarm contact with wire		Alarm contact with Terminal		
	Left	Right	Left	Right 3P	Right 4P
HDM3-100L/S	HDM3100SAL1L	HDM3100SAL1R	HDM3100SAL2L	HDM3100SAL2R3P	HDM3100SAL2R4P
HDM3-100T/N HDM3L-125	HDM3100FNAL1L	HDM3100FNAL1R	HDM3100FNAL2L	HDM3100FNAL2R3P	HDM3100FNAL2R4P
HDM3-160/250 HDM3E-125/250 HDM3L-160/250	HDM3250AL1L	HDM3250AL1R	HDM3250AL2L	HDM3250AL2R3P	HDM3250AL2R4P
HDM3-400/630 HDM3E-400/630/800 HDM3L-400	HDM3630AL1L	HDM3630AL1R	HDM3630AL2L	HDM3630AL2R3P	HDM3630AL2R4P
HDM3-800 HDM3L-630	HDM3800AL1L	—	HDM3800AL2L	—	—

Note: Right side mounted part is not adept with HDM3L MCCB

LOW VOLTAGE DISTRIBUTION

HDM3/3L/3E Series MCCB



Frame Size	Auxiliary Alarm with wire		Auxiliary Alarm with Terminal		
	Left	Right	Left	Right 3P	Right 4P
HDM3-100L/S	HDM3100SOFAL1L	HDM3100SOFAL1R	HDM3100SOFAL2L	HDM3100SOFAL2R3P	HDM3100SOFAL2R4P
HDM3-100T/N HDM3L-125	HDM3100FNOFAL1L	HDM3100FNOFAL1R	HDM3100FNOFAL2L	HDM3100FNOFAL2R3	HDM3100FNOFAL2R4
HDM3-160/250 HDM3E-125/250 HDM3L-160/250	HDM3250OFAL1L	HDM3250OFAL1R	HDM3250OFAL2L	HDM3250OFAL2R3P	HDM3250OFAL2R4P
HDM3-400/630 HDM3E-400/630/800 HDM3L-400	HDM3630OFAL1L	HDM3630OFAL1R	HDM3630OFAL2L	HDM3630OFAL2R3P	HDM3630OFAL2R4P
HDM3-800 HDM3L-630	HDM3800OFAL1L	—	HDM3800OFAL2L	—	—

Note: Right side mounted part is not adept with HDM3L MCCB



Frame Size	Under voltage release with Terminal	
	Voltage	Left
HDM3-100L/S	AC230V	HDM363MNA2L
	AC400V	HDM363MNA3L
HDM-100T/N HDM3L-125	AC230V	HDM3100FNMNA2L
	AC400V	HDM3100FNMNA3L
HDM3-160/250 HDM3L-160/250 HDM3E-125/250	AC230V	HDM3E125250MNA2L
	AC400V	HDM3E125250MNA3L
HDM3-400/630 HDM3L-400 HDM3E-400/630/800	AC230V	HDM3E400630MNA2L
	AC400V	HDM3E400630MNA3L
HDM3-800 HDM3L-630	AC230V	HDM3800MNA2L
	AC400V	HDM3800MNA3L

Under voltage release with Terminal

LOW VOLTAGE DISTRIBUTION

HDM3/3L/3E Series MCCB



Frame Size	Voltage	Shunt release with wire		Shunt release with Terminal		
		Left	Right	Left	Right 3P	Right 4P
HDM3-100L/S	AC230V	—	HDM3100SMX1A2	—	HDM3100SMX2A23P	HDM3100SMX2A24P
	AC400V	—	HDM3100SMX1A3	—	HDM3100SMX2A33P	HDM3100SMX2A34P
	DC24V	—	HDM3100SMX1D2	—	HDM3100SMX2D23P	HDM3100SMX2D24P
HDM3-100T/N	AC230V	HDM3100FNMX1A2L	HDM3100FNMX1A2	HDM3100FNMX2A2L	HDM3100FNMX2A23P	HDM3100FNMX2A24P
	AC400V	HDM3100FNMX1A3L	HDM3100FNMX1A3	HDM3100FNMX2A3L	HDM3100FNMX2A33P	HDM3100FNMX2A34P
	DC24V	HDM3100FNMX1D2L	HDM3100FNMX1D2	HDM3100FNMX2D2L	HDM3100FNMX2D23P	HDM3100FNMX2D24P
HDM3-160/250 HDM3E-125/250 HDM3L-160/250	AC230V	HDM3250MX1A2L	HDM3250MX1A2	HDM3250MX2A2L	HDM3250MX2A23P	HDM3250MX2A24P
	AC400V	HDM3250MX1A3L	HDM3250MX1A3	HDM3250MX2A3L	HDM3250MX2A33P	HDM3250MX2A34P
	DC24V	HDM3250MX1D2L	HDM3250MX1D2	HDM3250MX2D2L	HDM3250MX2D23P	HDM3250MX2D24P
	DC110V	—	HDM3E125250MX1D11	—	HDM3E250MX2D113P	HDM3E250MX2D114P
	DC220V	—	HDM3E125250MX1D22	—	HDM3E250MX2D223P	HDM3E250MX2D224P
HDM3-400/630 HDM3E-400/630/800 HDM3L-400	AC230V	HDM3630MX1A2L	HDM3630MX1A2	HDM3630MX2A2L	HDM3630MX2A23P	HDM3630MX2A24P
	AC400V	HDM3630MX1A3L	HDM3630MX1A3	HDM3630MX2A3L	HDM3630MX2A33P	HDM3630MX2A34P
	DC24V	HDM3630MX1D2L	HDM3630MX1D2	HDM3630MX2D2L	HDM3630MX2D23P	HDM3630MX2D24P
	DC110V	—	HDM3E400630MX1D11	—	HDM3E630MX2D113P	HDM3E630MX2D114P
	DC220V	—	HDM3E400630MX1D22	—	HDM3E630MX2D223P	HDM3E630MX2D224P
HDM3-800 HDM3L-630	AC230V	HDM3800MX1A2L	HDM3800MX1A2R	HDM3800MX2A2L	HDM3800MX2A2R3P	HDM3800MX2A2R4P
	AC400V	HDM3800MX1A3L	HDM3800MX1A3R	HDM3800MX2A3L	HDM3800MX2A3R3P	HDM3800MX2A3R4P
	DC24V	HDM3800MX1D2L	HDM3800MX1D2R	HDM3800MX2D2L	HDM3800MX2D2R3P	HDM3800MX2D2R4P

Note: Right side mounted part is not adept with HDM3L MCCB

LOW VOLTAGE DISTRIBUTION

HDM3/3L/3E Series MCCB



Front connection



Rear connection

Frame Size	Plug-in		
	Connection type	3P	4P
HDM3-100L/S	Front connection	HDM3100SPFC3	HDM3100SPFC4
	Rear connection	HDM3100SPRC3	HDM3100SPRC4
HDM3-100T/N	Front connection	HDM3100FNPF3	HDM3100FNPF4
	Rear connection	HDM3100FNPR3	HDM3100FNPR4
HDM3-160/250L/S	Front connection	HDM3250SPFC3	HDM3250SPFC4
	Rear connection	HDM3250SPRC3	HDM3250SPRC4
HDM3-160/250M/F/T/N HDM3E-125/250	Front connection	HDM3E125250PFC3	HDM3E125250PFC4
	Rear connection	HDM3E125250PRC3	HDM3E125250PRC4
HDM3-400 HDM3E-400 HDM3-630 HDM3E-630	Rear connection	HDM3E630PRC3	HDM3E630PRC4
HDM3-800	Rear connection	HDM3800PRC3	HDM3800PRC4
HDM3E-800	Rear connection	HDM3E800PRC3	HDM3E800PRC4



Frame Size	Motor		
	AC230V	AC400V	DC220V
HDM3-100L/S	HDM3100SD1A2	HDM3100SD1A3	HDM3100SD2
HDM3-100T/N	HDM3100FND1A2	HDM3100FND1A3	HDM3100FND2
HDM3-160/250L/S HDM3-160/250M/F/T/N	HDM3250FD1A2	HDM3250FD1A3	HDM3250FD2
HDM3E-125/250	HDM3E125250D2	HDM3E125250D4	—
HDM3-630 HDM3E-630	HDM3630D1A2	HDM3630D1A3	HDM3630D2
HDM3-800	HDM3800D1A2	HDM3800D1A3	—
HDM3E-800	HDM3E800D2	HDM3E800D4	—

LOW VOLTAGE DISTRIBUTION

HDM3/3L/3E Series MCCB



Frame Size	Rotation Handle		
	Handle shape	Direct	Extended (Default 150mm)
HDM3-100L/S	Round	HDM3100SH1	HDM3100SHL1
	Square	HDM3100SH2	HDM3100SHL2
HDM3-100T/N	Round	HDM3100FNH1	HDM3100FNHL1
	Square	HDM3100FNH2	HDM3100FNHL2
HDM3-160/250	Round	HDM3250H1	HDM3250HL1
	Square	HDM3250H2	HDM3250HL2
HDM3-400/630	Round	HDM3630H1	HDM3630HL1
	Square	HDM3630H2	HDM3630HL2
HDM3-800	Round	HDM3800H1	HDM3800HL1
	Square	HDM3800H2	HDM3800HL2
HDM3E-125/250	Round	HDM3E125250H1	HDM3E125250HL1
	Square	HDM3E125250H2	HDM3E125250HL2
HDM3E-400/630	Round	HDM3E400630H1	HDM3E400630HL1
	Square	HDM3E400630H2	HDM3E400630HL2
HDM3E-800	Round	HDM3E800H1	HDM3E800HL1
	Square	HDM3E800H2	HDM3E800HL2



Round



Square

Note: Default length of rod is 150mm. On further requirement, please order below rod individually.

	300mm
Under 250A:	HDM3-8x8ROD300
Over 250A:	HDM3-10x10ROD300

Frame Size	Draw-out		
	Connection type	3P	4P
HDM3-400 HDM3E-400	Horizontal connection	HDM3E400DOR3	HDM3E400DOR4
HDM3-630 HDM3E-630	Horizontal connection	HDM3E630DOR3	HDM3E630DOR4
HDM3E-800	Horizontal connection	HDM3E800DOR3	HDM3E800DOR4



HDM3/3L/3E Series MCCB



Frame Size	Expanding terminal	
	3P(3pcs)	4P(4pcs)
HDM3-100L/S	DM3100FNC3	HDM3100FNC4
HDM3-100T/N HDM3L-125		
HDM3-160/250L/S HDM3-160/250M/F/T/N HDM3L-160/250 HDM3E-125/250	HDM3250C3	HDM3250C4
HDM3-400 HDM3L-400 HDM3E-400	HDM3400C3	HDM3400C4
HDM3-630 HDM3E-630	HDM3630C3	HDM3630C4
HDM3-800 HDM3E-800 HDM3L-630	HDM3E800C3	HDM3E800C4



Frame Size	Modbus RTU module
HDM3E-125	HDM3ECOM
HDM3E-250	
HDM3E-400	
HDM3E-630	
HDM3E-800	



Frame Size	Interphase barriers	
	3P(2pcs)	4P(3pcs)
HDM3-100L/S	HDM3100SIB3	HDM3100SIB4
HDM3-100T/N HDM3L-125	HDM3100FNIB3	HDM3100FNIB4
HDM3-160/250L/S	HDM3250SIB3	HDM3250SIB4
HDM3-160/250M/F/T/N HDM3L-160/250 HDM3E-125/250	HDM3250FIB3	HDM3250FIB4
HDM3-400 HDM3L-400 HDM3E-400 HDM3-630 HDM3E-630	HDM3630IB3	HDM3630IB4
HDM3-800 HDM3L-630	HDM3800IB3	HDM3800IB4
HDM3E-800	HDM3E800IB3	HDM3E800IB4

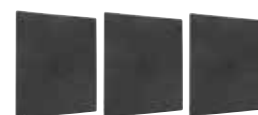

LOW VOLTAGE DISTRIBUTION

HDM3/3L/3E Series MCCB



Frame Size	Rear connection	
	3P(6pcs)	4P(8pcs)
HDM3-100L/S	HDM363RC3	HDM363RC4
HDM3-100T/N HDM3L-125	HDM3100FNRC3	HDM3100FNRC4
HDM3-160/250 HDM3L-160/250 HDM3E-125/250	HDM3250RC3	HDM3250RC4
HDM3-400/630 HDM3L-400 HDM3E-400/630	HDM3630RC3	HDM3630RC4
HDM3-800 HDM3E-800 HDM3L-630	HDM3800RC3	HDM3800RC4



Frame Size	Terminals	Torque	Cross-section of cable/mm ²	Minimum order quantity
HDM3-100L/S	LUG100S1E (Extend)	12	20~70	84pcs/box
HDM3-100T/N HDM3L-125	LUG100F1 (Normal)	12	20~70	84pcs/box
	LUG100F1E (Extend)	12	20~70	84pcs/box
HDM3-160 HDM3L-160 HDM3E-125	LUG1601 (Normal)	20	25~200	36pcs/box
	LUG1601E (Extend)	20	25~200	24pcs/box
HDM3-160/250 HDM3L-160/250 HDM3E-125/250	— (Normal)	—	—	—
	LUG2502E (Extend)	20	25~150	12pcs/box
HDM3-400 HDM3L-400 HDM3E-400	LUG4001 (Normal)	30	95~240	12pcs/box
	LUG4001E (Extend)	35	50~240	12pcs/box
HDM3-400/630 HDM3L-400 HDM3E-400/630	— (Normal)	—	—	—
	LUG6302E (Extend)	35	50~240	6pcs/box
HDM3-800 HDM3L-630 HDM3E-800	— (Normal)	—	—	—
	LUG8004E (Extend)	35	50~240	3pcs/box



HDM3E-1600A Accessories		
Acc Name	AC230V	AC400V
Close release	HDW3XF2A	HDW3XF3A
Shunt release	HDW3MX2A	HDW3MX3A
Undervoltage release	HDW3MN2A	HDW3MN3A
Motor	HDW3MCH162A	HDW3MCH163A



1600A Accessories		
Acc Name	AC220~400V Input	DC220/110V Input
Power module	IAPU334	IAPU332D



HDM3/3L/3E Series MCCB



Dimensions and connection HDM3/HDM3L/HDM3E 125-800

Fixed MCCB mounting dimension
Front connection(mm)

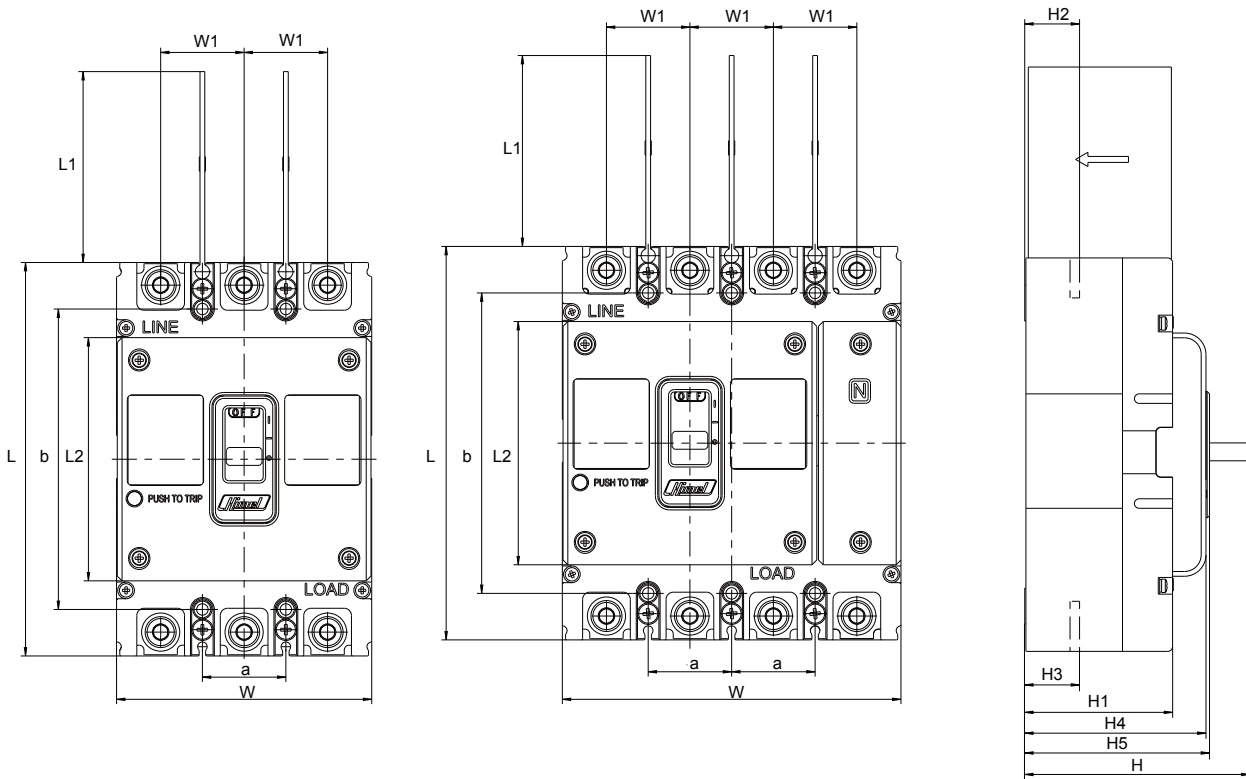

Product type	Poles	Overall dimension											Installation dimension		
		L	L1	L2	W	W1	H	H1	H2	H3	H4	H5	a1	a2	b
HDM3-100L/S	3/4	130	50	83	75/100	25	81.5	54	24	24	68	70.5	25	25	111
HDM3-100T/N HDM3L-125	3/4	150	50	96	92/122	30	111.5	81	28.5	28	93.5	95.5	30	30	129
HDM3-160/250S	3/4	165	50	102	107/142	35	94.5	62	23	23	76	77.5	35	35	126
HDM3-160/250FN HDM3L-160/250	3/4	165	80	102	107/142	35	112.5	80	23	23	94	95.5	35	35	126
HDM3E-125								86	21.5						
HDM3E-250								86	23						
HDM3-400 HDM3L-400	3/4	257	104.5	102	150/198	48	145.9	96.2	36	36.5	107.5	112.5	44	44	215
HDM3E-400				161.5										-	
HDM3-630				150										44	
HDM3E-630				161.5										-	
HDM3L-630	3/4	280	102	102	210/280	70	160	108	40.5	41.5	111	119	70	70	243
HDM3-800	3/4	280	104.5	102	210/280	70	146.5	97.5	32.5	35.5	100	114	70	70	243
HDM3E-800				170			154	103	40.5	47	116	121			

HDM3/3L/3E Series MCCB



Fixed front installation hole dimensions

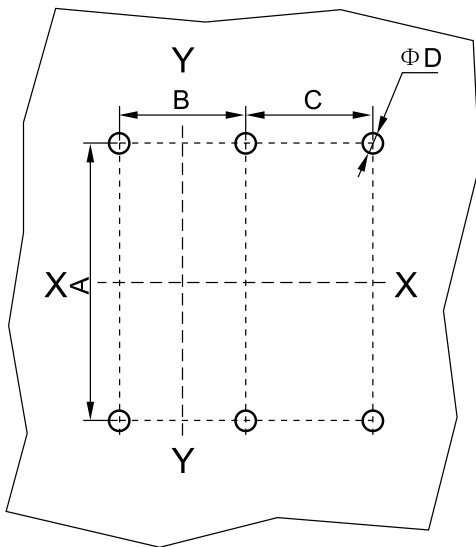

Note: X-X and Y-Y is the center of the three-pole breaker

Product type	Poles	Installation dimension			
		A	B	C	D
HDM3-100L/S	3	111	25	/	4.5
	4	111	25	25	
HDM3-100T/N HDM3L-125	3	129	30	/	5
	4	129	30	30	
HDM3-160/250 HDM3L-160/250	3	126	35	/	5.5
	4	126	35	35	
HDM3-400/630 HDM3L-400	3	215	44	/	6.5
	4	215	44	/	
HDM3L-630	3	243	70	/	7.5
	4	243	70	70	
HDM3-800	3	243	70	/	7.5
	4	243	70	70	
HDM3E-800	3	243	70	/	7.5
	4	243	70	70	

HDM3/3L/3E Series MCCB



Fixed and insert type breaker panel cut off dimensions

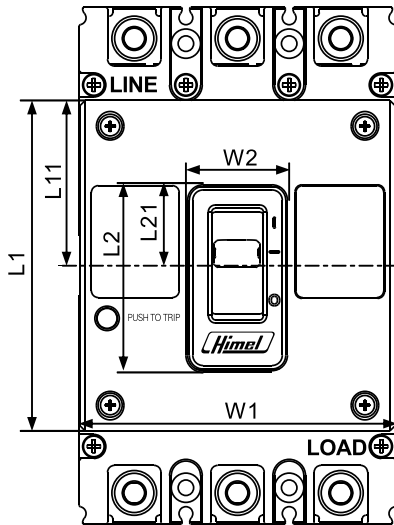

HDM3L 125-800 3P

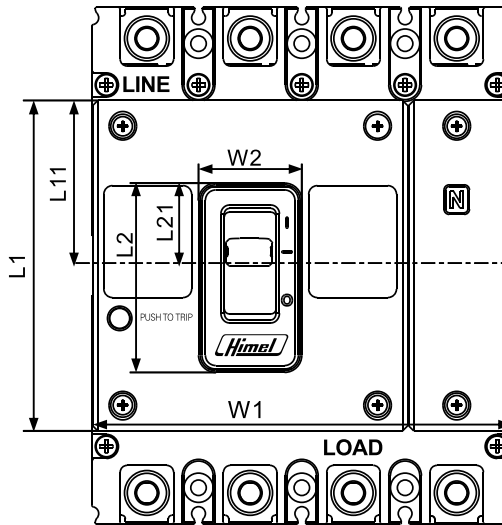

HDM3L 125-800 4P

Model	Poles	Exposed front cover			Exposed toggle handle		
		W1	W2	L11	W2	L2	L21
HDM3-100L/S	3P	75	83	41.5	22	50	26
	4P	100	83	41.5	22	50	26
HDM3-100T/N HDM3L-125	3P	92	96	48	30	55	24
	4P	122	96	48	30	55	24
HDM3-160 HDM3-250 HDM3L-160 HDM3L-250	3P	107	102	51	26	54	27
	4P	142	102	51	26	54	27
HDM3-400 HDM3-630 HDM3L-400	3P	150	150	75	52.5	75.5	41
	4P	198	150	75	52.5	75.5	41
HDM3-800 HDM3L-630	3P	210	200	100	65	105	51
	4P	280	200	100	65	105	51

HDM3/3L/3E Series MCCB



Hole dimensions of fixed and inserted panels (mm)

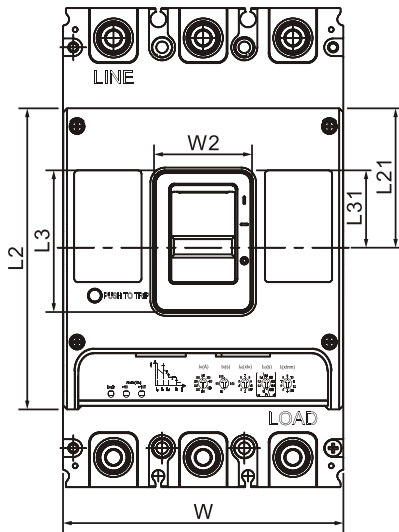

HDM3E 125-800 4P

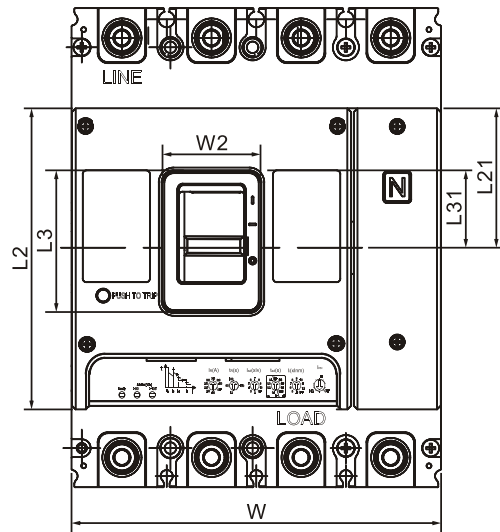

HDM3E 125-800 4P

Notes: dimension shown in the table is the actual dimension of the product
Please control the clearance of installation on your own

Product Model	Poles	Exposed Panel and toggle handle			Only the toggle handle is exposed		
		W	L2	L21	W2	L3	L31
HDM3E-125/250	3	107	102.5	51	26	50.5	26.5
	4	142					
HDM3E400/630	3	150	161.5	75	52.5	75.5	41
	4	198					
HDM3E-800	3	210	170	67.5	55	85	42.5
	4	280					

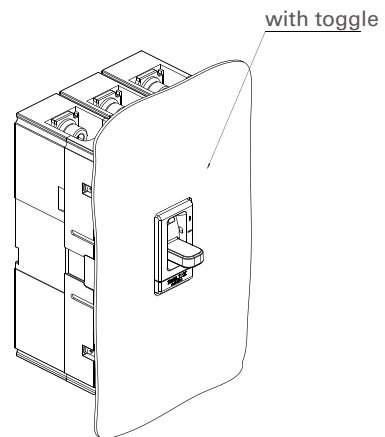
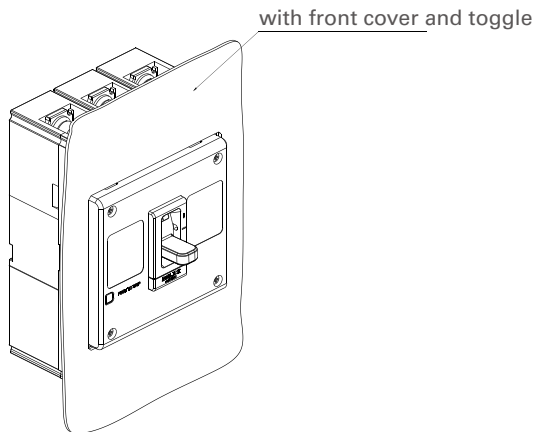

HDM3/3L/3E Series MCCB



Rear connection (mm)

Product type	H1	H2	D
HDM3-100L/S	80	67	8
HDM3-100T/N	97	47	8
HDM3-160	102	72	10
HDM3-250	102	72	10
HDM3E-125/250	102	72	10

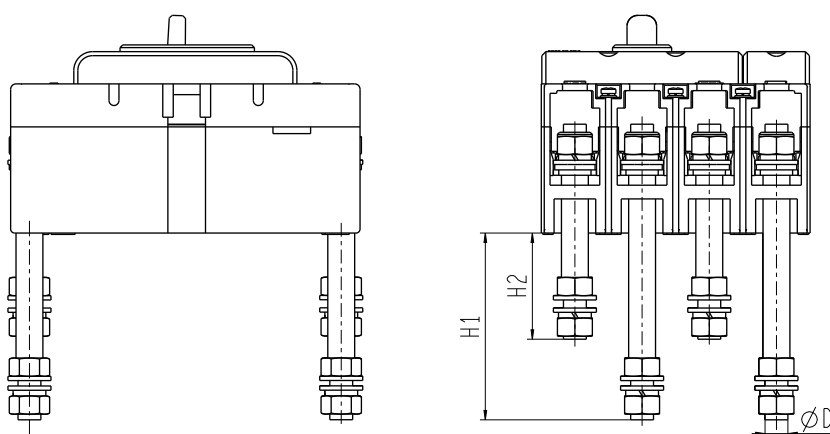

Under 250A dimension drawing

Installation dimensions

Product type	H1	H2	D
HDM3-400	98	134	12.5
HDM3-630	98	134	12.5
HDM3-800	107	141	12.5
HDM3E-400/630	92	128	12.5
HDM3E-800	129	129	13

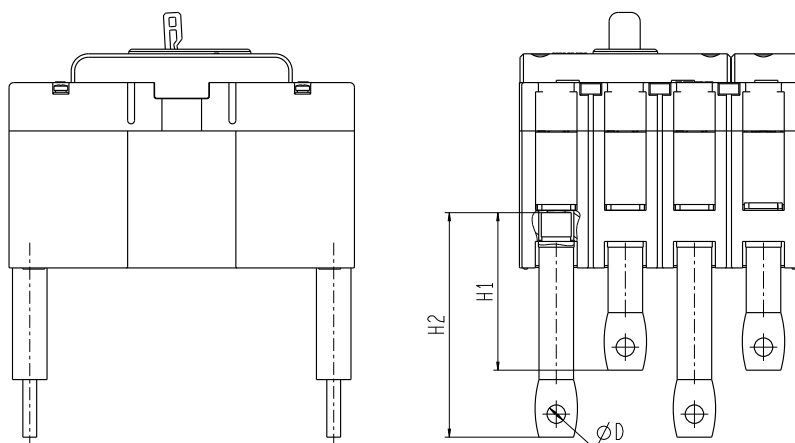

Above 250A dimension drawing

HDM3/3L/3E Series MCCB



Fixed rear installation hole dimensions

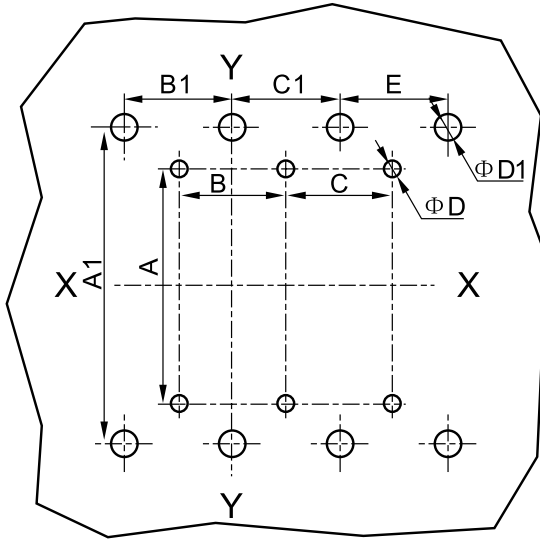

Note: X-X and Y-Y is the center of the three-pole breaker

Product type	Poles	A	B	C	D	A1	B1	C1	E	D
HDM3-100L/S	3	111	25	/	4.5	116	25	25	/	12
	4			25					25	
HDM3-100T/N	3	129	30	/	5	132	30	30	/	12
	4			30					30	
HDM3-160/250 HDM3E-125/250	3	126	35	/	5.5	145	35	35	/	15
	4			35					35	
HDM3-400/630	3	215	44	/	6.5	225	48	48	/	18
	4			/					48	
HDM3E-400/630	3	215	44	/	6.5	225	48	48	/	32
	4			/					48	
HDM3-800	3	243	70	/	7.5	243	70	70	/	27
	4			70					70	
HDM3E-800	3	243	70	/	7.5	243	70	70	/	40
	4			70					70	

HDM3/3L/3E Series MCCB



Plug-in MCCB mounting dimension

Front connection(mm)

Product type	A	B	E	F	G _(3P/4P)	H	L _(3P/4P)	L1	L2	M	N	K	d
HDM3-100L/S	91.5	48.2	111	60	50/75	145	75/100	25	25	190	173	22.5	6
HDM3-100T/N	100.5	56.2	132	67	60/90	170	90/120	30	30	216	198	25	6.5
HDM3-160/250 HDM3E-125/250	108.5	73.2	144	74	70/105	191	105/140	35	35	243	223	37.5	8.5

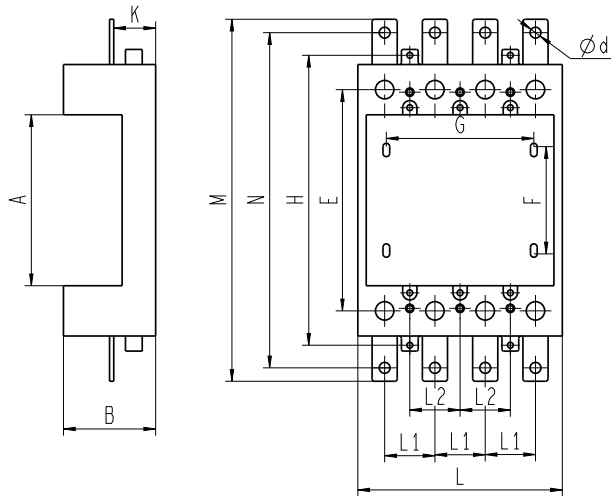

Plug-in front hot position drawing

Product type	Number of poles	A1	B1	D
HDM3-100L/S	3	50	60	5.5
	4	75		
HDM3-100T/N	3	60	67	6.5
	4	90		
HDM3-160/250 HDM3E-125/250	3	70	74	6.5
	4	105		

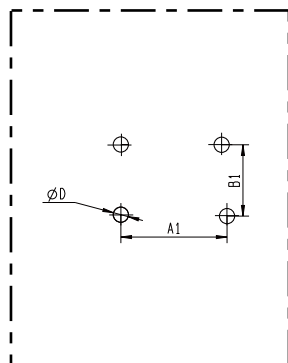

HDM3/3L/3E Series MCCB



Rear connection(mm)

	A	B	C	D	E	F	G(3/4P)	H	L(3/4P)	L1	L2
HDM3-100L/S	91.5	48.2	154	M3	111	60	50/75	145	75/100	25	25
HDM3-100T/N	100.5	56.2	180	M4	132	67	60/90	170	90/100	30	30
HDM3-160/250 HDM3E-125/250	108.5	73.2	203	M4	144	74	70/105	191	105/140	35	35
HDM3-400/630 HDM3E-400/630	170	60	/	/	225	130	60/108	/	152/200	48	44
HDM3800	187	62	/	/	243	143	140/210	/	210/280	70	70
HDM3E-800	187	125	342	M5	243	143	140/210	328	210/280	70	70

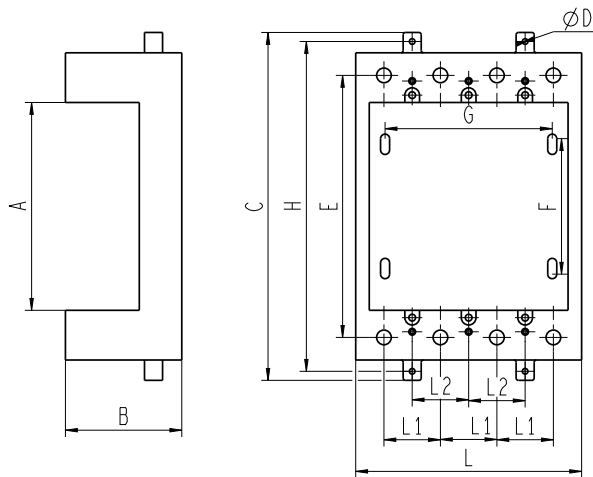

Product type	Poles	A	A1	B	B1	C	D
HDM3-100L/S	3	79	50	30	60	90	5.5
	4	104	75				
HDM3-100T/N	3	94	60	40	67	90	6.5
	4	124	90				
HDM3-160/250 HDM3E-125/250	3	110	70	45	74	100	6.5
	4	145	105				
HDM3-400/630 HDM3E-400/630	3	157	88	60	145	170	8.5
	4	205	132				
HDM3-800	3	212	140	62	143	185	11
	4	282	210				
HDM3E-800	3	212	140	64	143	185	11
	4	282	210				

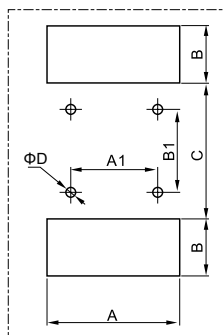

HDM3/3L/3E Series MCCB



Draw out mounting dimension

Rear connection(mm)

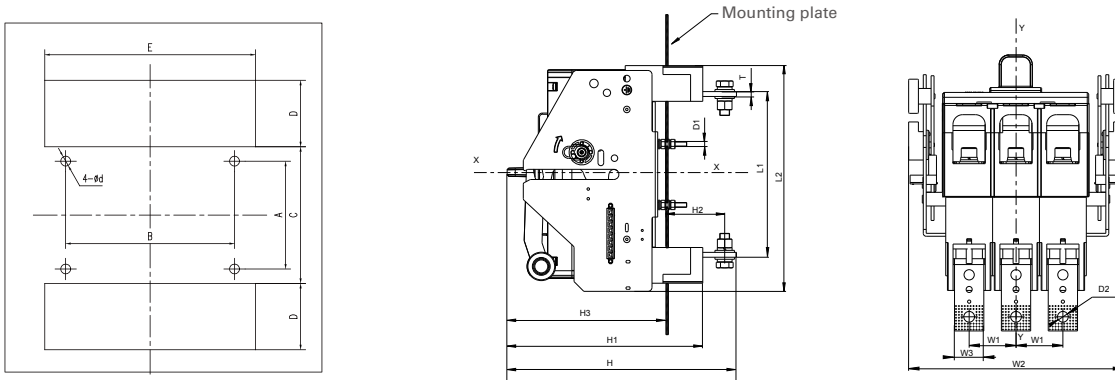

Product type	Poles	Installation Dimensions						Dimensions										
		A	B	C	D	E	d	L1	L2	H	H1	H2	H3	W1	W2	W3	φD1	φD2
HDM3-400	3	140	96	178	47	147	7	203	269	281	240	77	189	48	223	30	φ6.2	φ11
HDM3E-400	4	140	144	178	47	195	7	203	269	281	240	77	189	48	271	30	φ6.2	φ11
HDM3-630	3	140	96	178	47	147	7	207	269	281	240	77	189	48	223	30	φ6.2	φ11
HDM3E-630	4	140	144	178	47	195	7	207	269	281	240	77	189	48	271	30	φ6.2	φ11
HDM3-800	3	131	140	170	77	213	7	241	317	302	250	73	208	70	289	40	φ6.2	φ13
HDM3E-800	4	131	210	170	77	283	7	241	317	302	250	73	208	70	359	40	φ6.2	φ13
HDM3-800	3	131	140	170	77	213	7	241	317	302	250	73	208	70	289	40	φ6.2	φ13
HDM3E-800	4	131	210	170	77	283	7	241	317	302	250	73	208	70	359	40	φ6.2	φ13

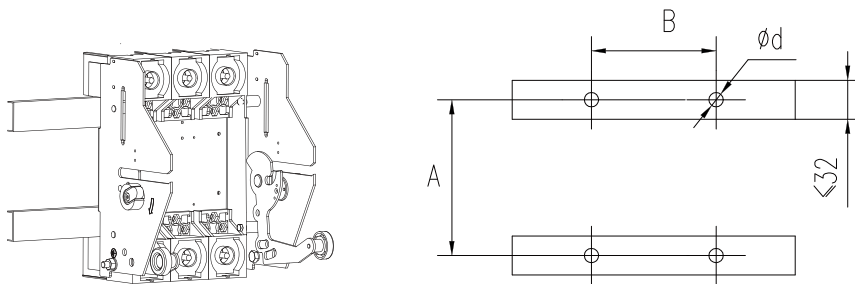

Product type	Poles	Installation Dimensions		
		A	B	d
HDM3-400	3	140	96	7
HDM3E-400	4	140	144	7
HDM3-630	3	140	96	7
HDM3E-630	4	140	144	7
HDM3-800	3	131	140	7
HDM3E-800	4	131	210	7

HDM3/3L/3E Series MCCB



Rotary handle dimension

Handle operation mechanism installation

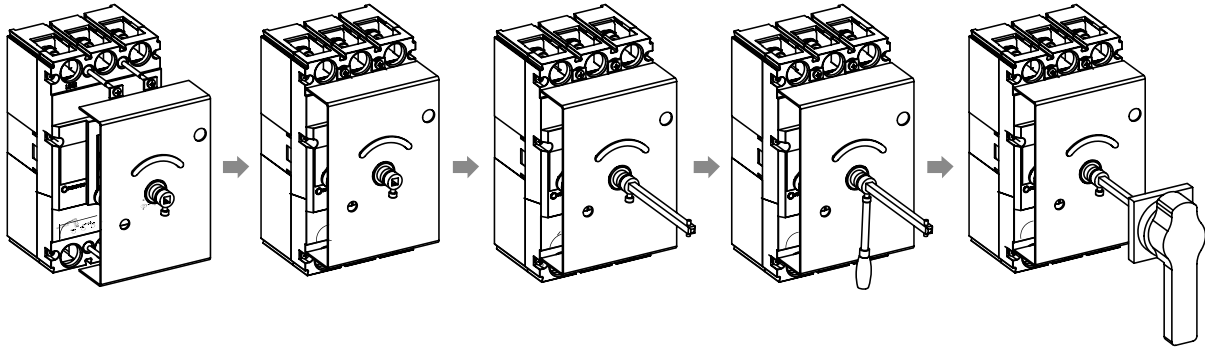

Mounting with MCCB dimensions(mm)

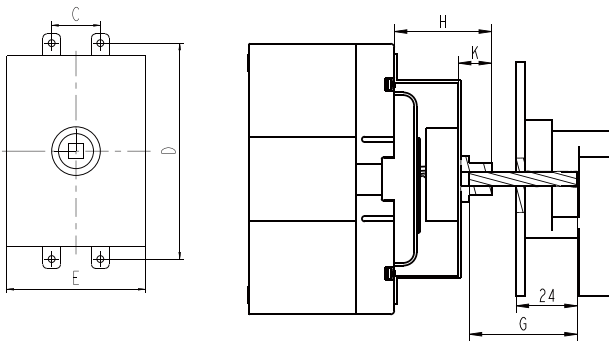

Product type	C	D	E	H	K
HDM3-100L/S	25	111	75	54	20
HDM3-100T/N	30	129	92	57	20
HDM3-160/250	35	143	100	54	20
HDM3E-125/250	35	143	100	49	20
HDM3-400/630	44	215	150	78	20
HDM3E-400/630	44	215	140	76	20
HDM3-800A	70	243	/	76	20
HDM3E-800A	70	243	210	76	20

Installation hole dimensions

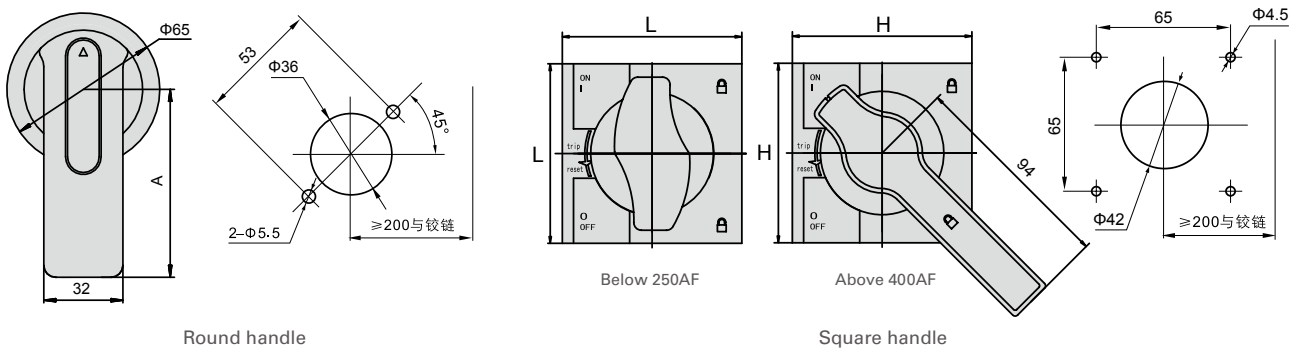

Round handle

Square handle

Product type	Round handle	Square handle	
	A	L	H
HDM3-100L/S	65	80	80
HDM3-100T/N	65	80	80
HDM3-160/250	65	80	80
HDM3E-125/250	65	80	80
HDM3-400/630	95	80	80
HDM3E-400/630	95	80	80
HDM3-800	95	80	80
HDM3E-800	95	80	80

HDM3/3L/3E Series MCCB



Motor Mounted with MCCB Dimensions (mm)

Installation of electric operating mechanism

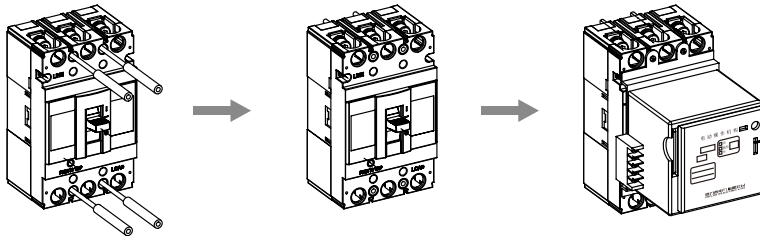

After tripping of the breaker with an electrically operated mechanism, the electrically operated mechanism must be opened first before closed.

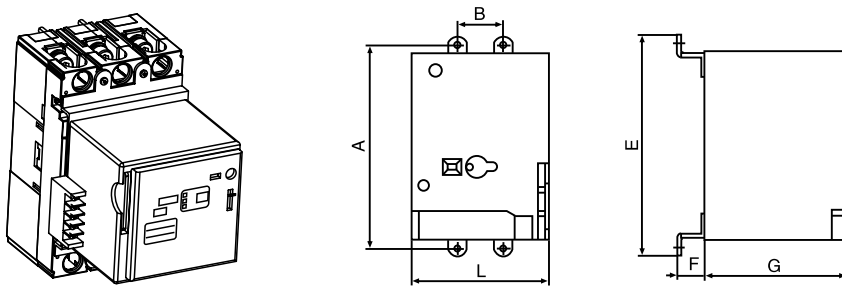

Product type	A	B	E	F	G	L
HDM3-100L/S	111	25	120	15	79	74
HDM3-100T/N	129	30	140	16	77	90
HDM3-160/250	126	35	140	17	77	90
HDM3E-125/250	126	35	140	12	77	90.5
HDM3-400/630	215	44	232	32	115	130
HDM3E-400/630						
HDM3-800	243	70	/	31	115	/
HDM3E-800	243	70	260	31	115	130

HDM3/3L/3E Series MCCB



Terminal Connection Dimensions (mm)

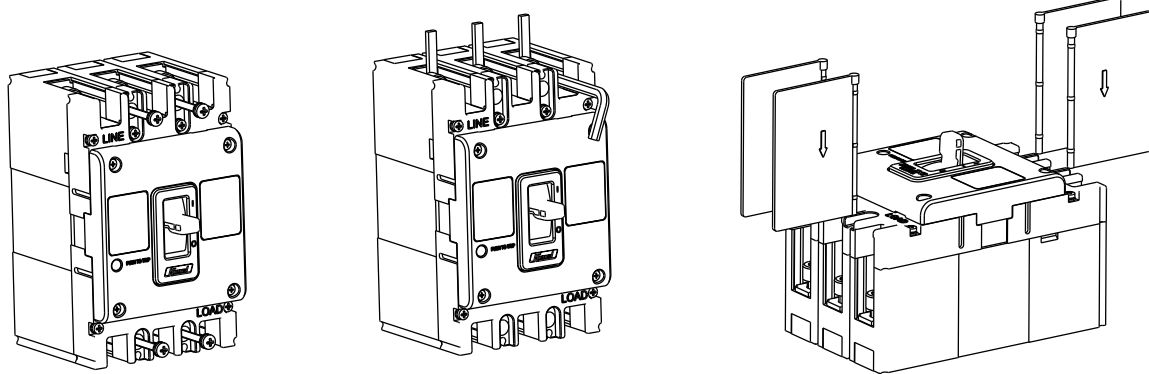

Connection terminal and torque table

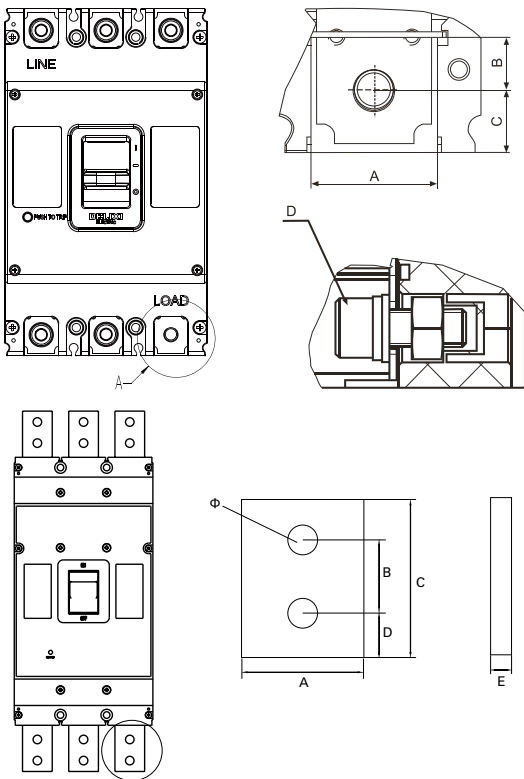

Product type	A	B	C	D	Torque(N.M)
HDM3-100L/S	16	7.5	7	M6	4-8
HDM3-100T/N HDM3L-125	18	7.5	9	M8	4-8
HDM3-160/250 HDM3L-160/250	25	12.5	9.5	M8	9.5-10.5
HDM3E-125/250	25.5	12	10	M8	9.5-10.5
HDM3-400/630 HDM3L-400	32	14	16	M10	19.5-20.5
HDM3E-400/630	32	13	16	M10	19.5-20.5
HDM3-800 HDM3L-630	44.5	12	16	M12	29.5-30.5
HDM3E-800	45.5	16.8	18.5	M12	29.5-30.5

Connecting conductor (mm²)

Rated current A	10	16 20	25	32	40 50	63	80	100	140	160	180 200 225	250	315	400
Cross-section of conductor	1.5	3	4	6	10	16	25	35	50	70	95	120	185	240

Rated current A	Quantity	Copper conductor or insulated copper wire Cross section mm ²	Copper busbar Size: mm x mm
500	2	150	30x5
630	2	185	40x5
700-800	2	240	50x5

HDM3/3L/3E Series MCCB



Expanding Terminal Information

Frame Size	Outside view	Size (mm)	QTY	
			3P	4P
HDM3-100 L/S/T/N HDM3L-125			3	4
HDM3-160/250L/S HDM3-160/250M/F/T/N HDM3L-160/250 HDM3E-1125/250			1	2
			2	2
HDM3-400 HDM3L-400 HDM3E-400 HDM3-630 HDM3E-630			2	2
			1	2
HDM3-800 HDM3E-800 HDM3L-630			3	4

Dimensions and Connection for HDM3E-1600

Fixed MCCB mounting dimension (mm)

Unit:mm

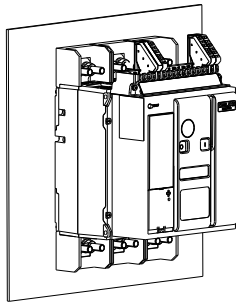
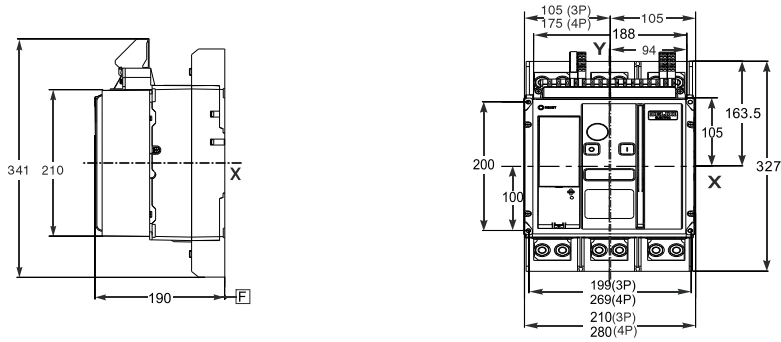

Installed on plate

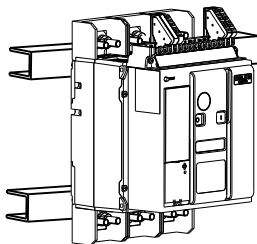
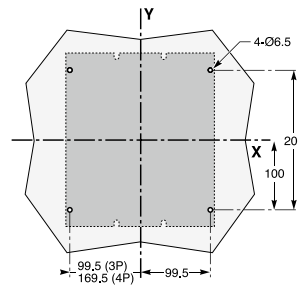

Installed on din rail

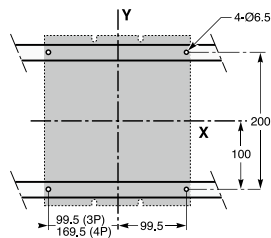

Note: X and Y are plane of symmetry of 3 pole breaker Z is back plane of breaker.

With doorframe:
Holes dimension on door

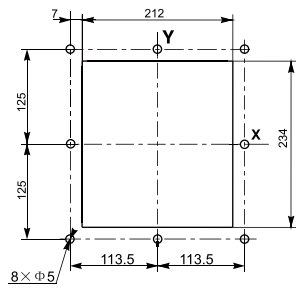

Without doorframe:
Holes dimension on door

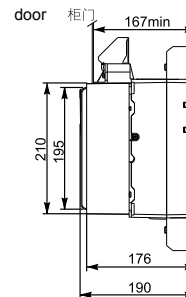
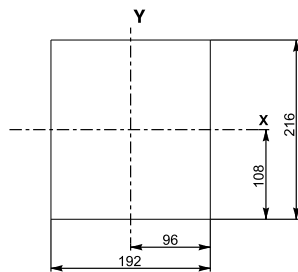

LOW VOLTAGE DISTRIBUTION

HDM3/3L/3E Series MCCB



Terminal connection dimensions (mm)

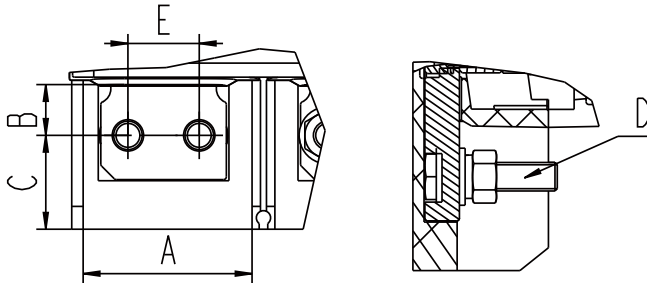

Product type	A	B	C	D	E	Torque(N.M)
HDM3E-1600	59	17.2	32.8	M10	25	50

Terminal and busbar dimensions (mm)

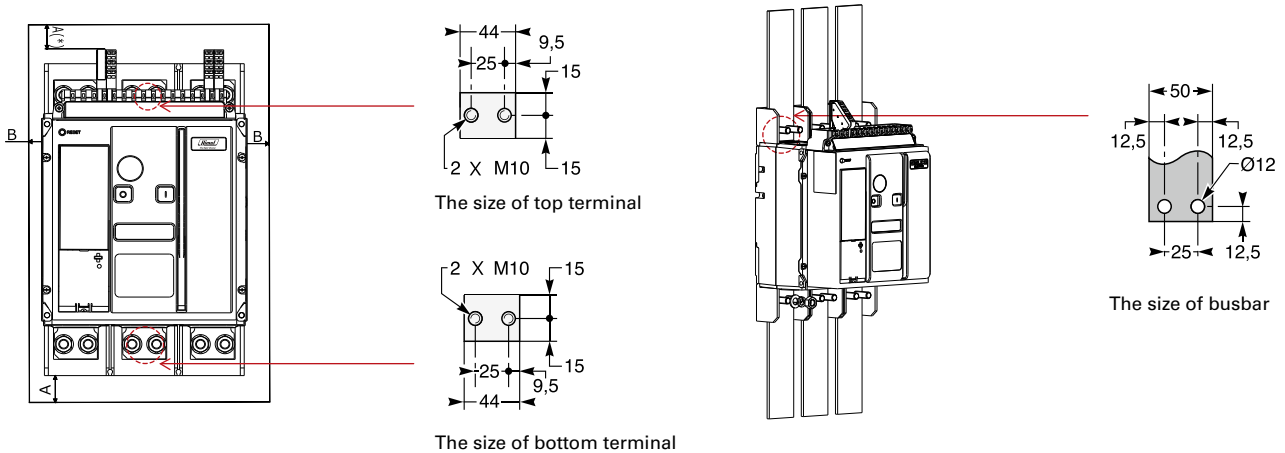

Max current	Ti:40°C the number of busbar		Ti:50°C the number of busbar		Ti:60°C the number of busbar	
	5mm Thickness	10mm Thickness	5mm Thickness	10mm Thickness	5mm Thickness	10mm Thickness
1000	3b.50x5	1b.63 x 10	3b.50x5	2b.50 X 10	3b.63x5	2b.50 x 10
1250	3b.50x5	2b.40 x 10	3b.50x5	2b.50 X 10	3b.63x5	2b.50 x 10
	2b.80x5	2b.40 x 10	2b.80x5			
1600	3b.80x5	2b.63 x 10	3b.80x5	2b.63 x 10	3b.80x5	2b.50 x 10

HDM3/3L/3E Series MCCB



Expanding terminal dimensions (mm)

Unit:mm

Extension terminal for A phase or B phase of 4 pole

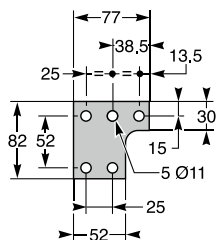

Extension terminal for B phase of 3 pole

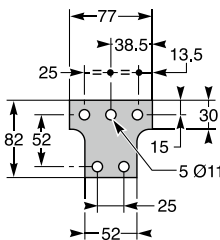

Extension terminal for N phase or C phase of 4 pole

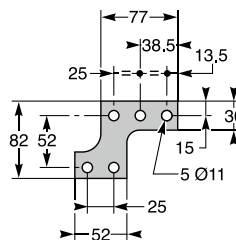

Extension terminal for A phase or C phase of 3 pole

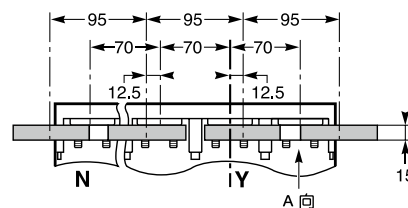
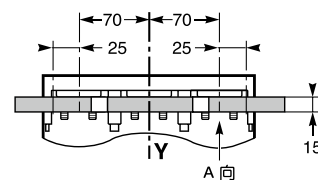
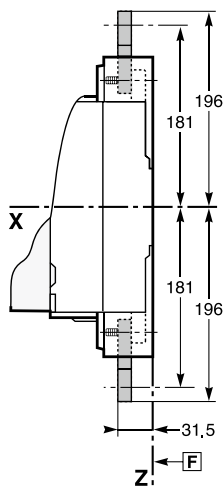
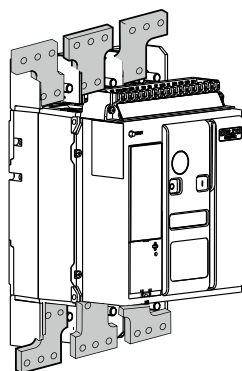
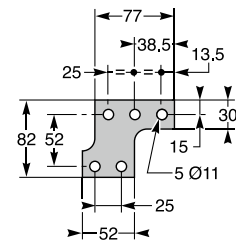

Dimensions of power module (35mm Dim rail fitted)

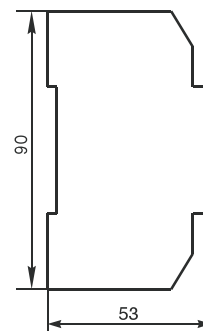
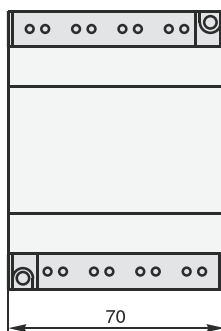
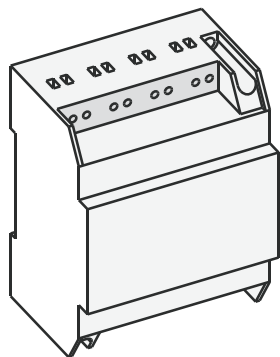

HDM3/3L/3E Series MCCB



Tripping curve

HDM3-100L/S

HDM3-100L/S 10~100A

Black line: power distribution protection,
red line: motor protection;

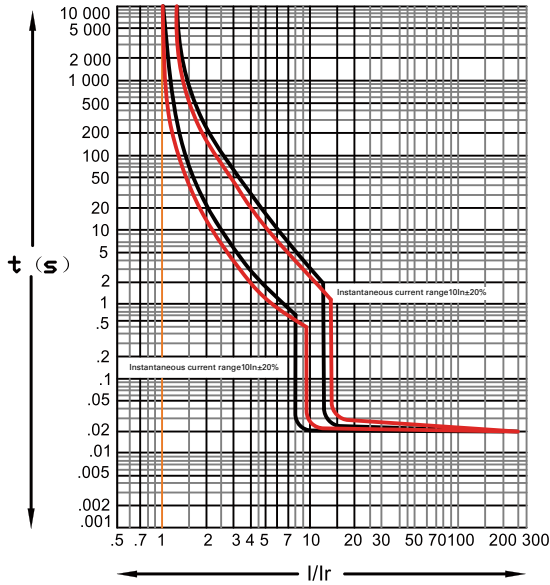

HDM3-100T/N

HDM3-100T/N 40A-100A

Black line: power distribution protection ,
red line: motor protection;

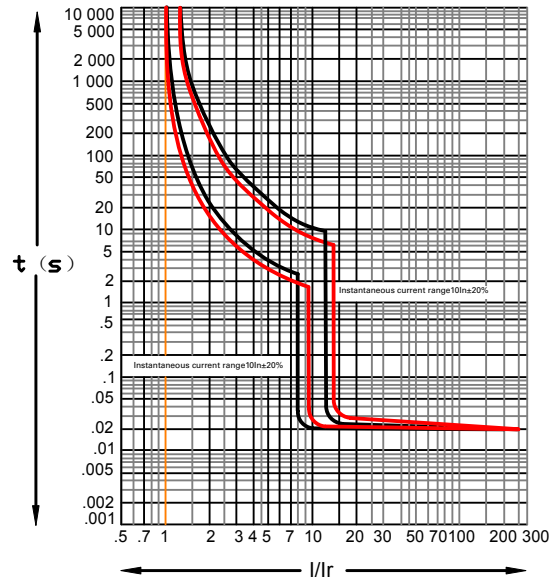

HDM3-160/250

Black line: power distribution protection ,
red line: motor protection;

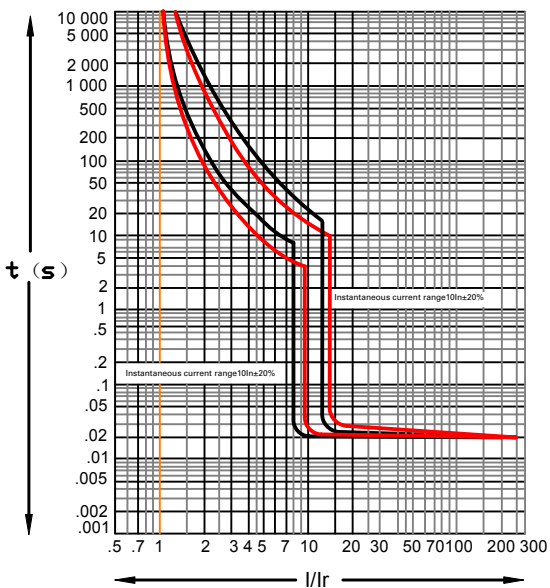

HDM3-400

Black line: power distribution protection ,
red line: motor protection;

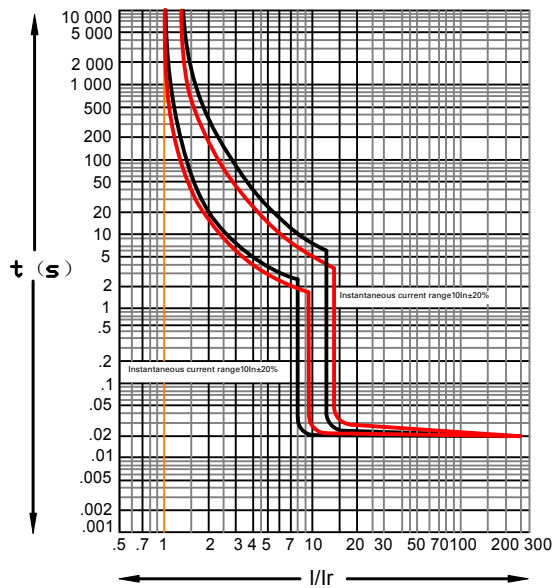

LOW VOLTAGE DISTRIBUTION

HDM3/3L/3E Series MCCB



HDM3-630

Black line: power distribution protection ,
red line: motor protection;

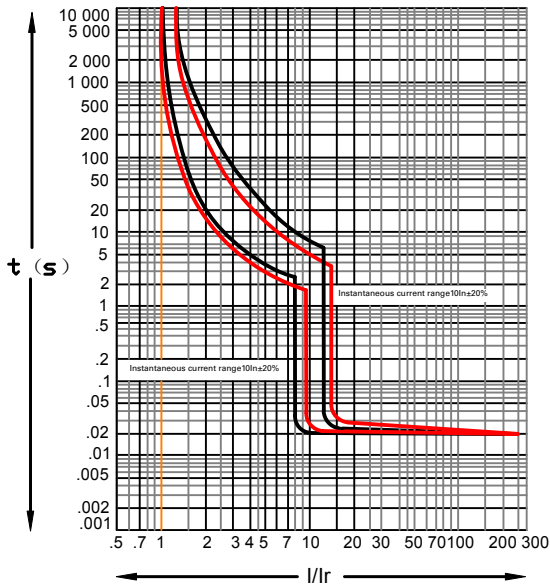

HDM3-800A

HDM3-800A 630A

For power distribution

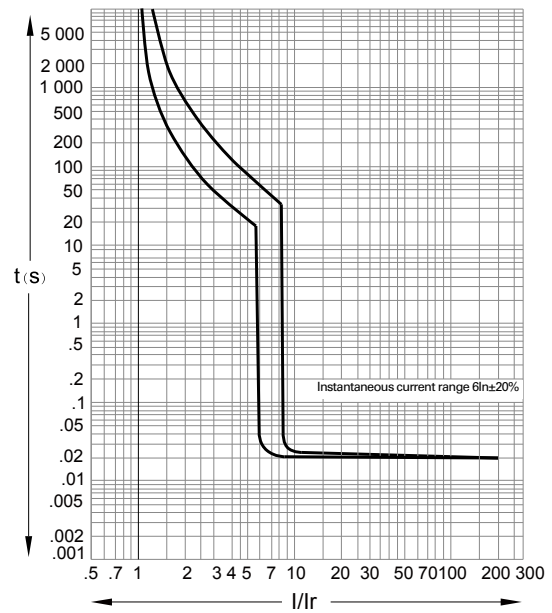
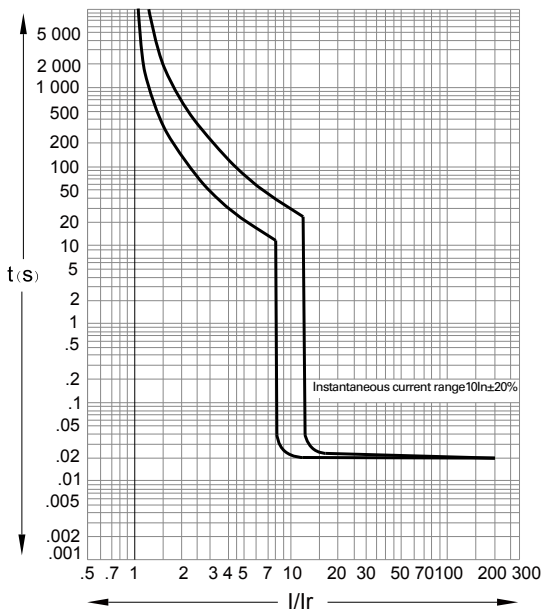

HDM3E(125~800AF) Tripping curve

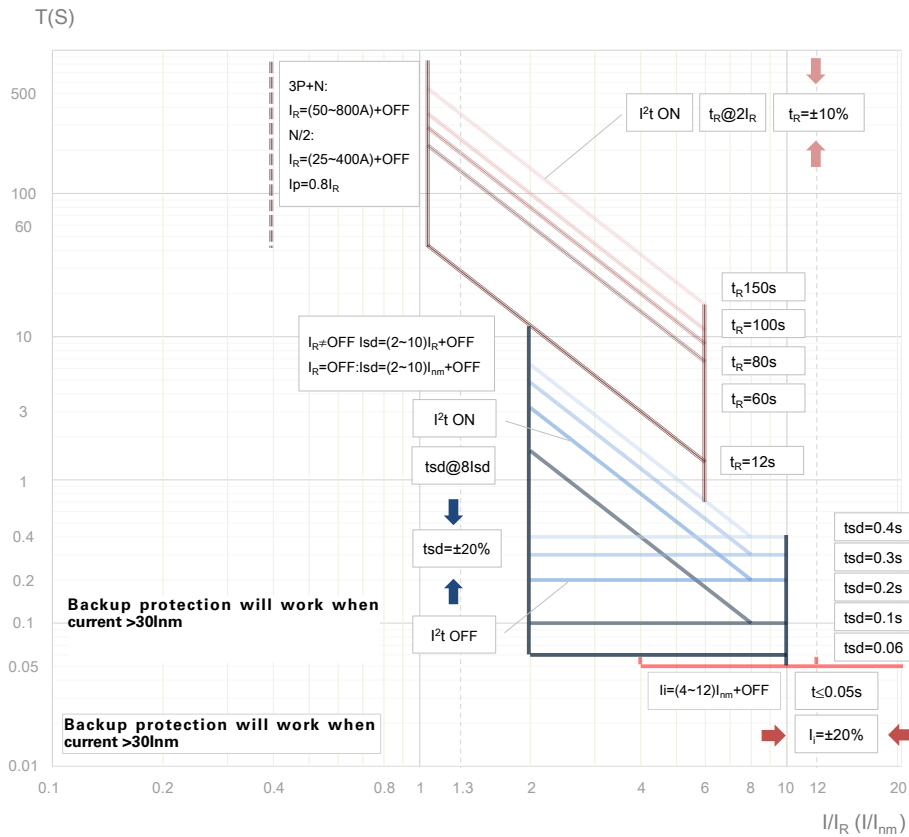

HDM3E-1600AF Tripping characteristic

Triple protection

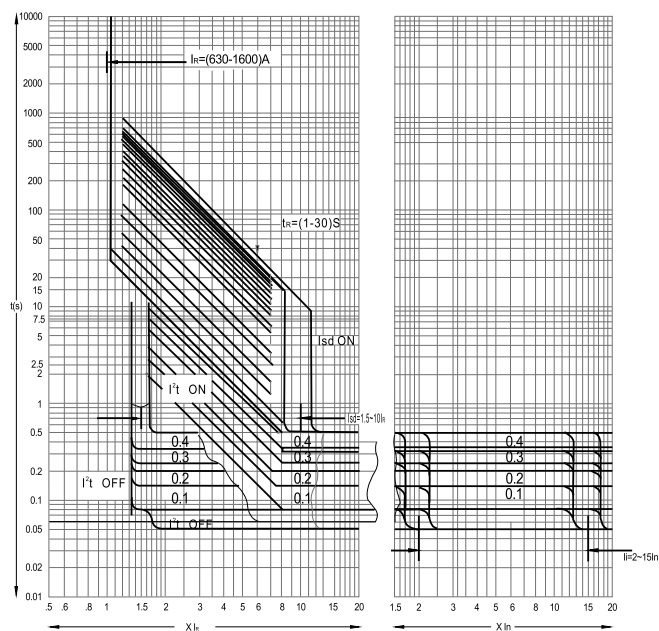

Underground protection

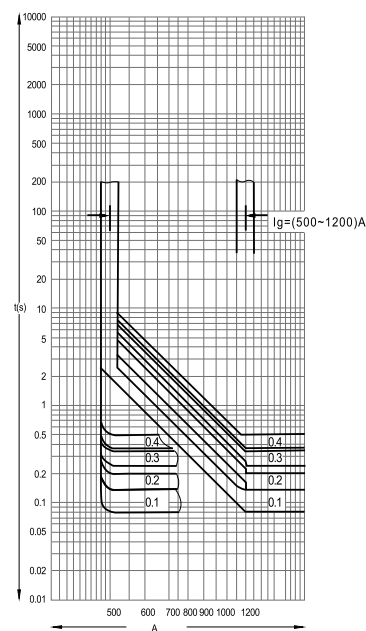

HDM3-1600 MCCB



Range Presentation

HDM3 is Himel 3 series range of molded case circuit breakers with fixed thermal magnetic trip unit, providing line protection and motor protection, up to 1600A.

HDM3E is Himel 3 series range of MCCB with electronic type trip unit, providing LSI protection, up to 1600A.

HDM3L is Himel 3 series range of earth leakage MCCB, providing protection against residual current, up to 630A.

Features

Easy Installation and Safe Operation

- ◆ Double-deck cover design assures easy installation and removal of accessories.

High Performance

- ◆ Patented design ensures quick extinguishing of arc.
- ◆ Suitable for wide environment conditions, max. -40°C~+70°C

Selection Guide

MCCB Selection Code-@40°products

Range Name	Frame Size	Breaking capacity (Icu/Ics)	Rated current	Poles	Protection
HDM3	1600	N	1600	3	3XX
HDM3 MCCB	1600: 1600A	N: 70/50	800,1000,1250,1600A	3: 3P	3XX: Mag-Therma line protection

Commercial Ref	Commercial Ref Desc
HDM31600N80033XX	HDM3-1600N 800A 3P 40°C
HDM31600N100033XX	HDM3-1600N 1000A 3P 40°C
HDM31600N125033XX	HDM3-1600N 1250A 3P 40°C
HDM31600N160033XX	HDM3-1600N 1600A 3P 40°C
HDM31600OF12K2BR	Auxiliary contact (Right/wire) 2NO+2NC HDM3-1600
HDM31600AL1R	Alarm (Right/wire HDM3-1600
HDM31600OFAL1R	Auxiliary/Alarm (Right/wire) HDM3-1600
HDM31600HL2	Square Extended Rotation Handle HDM3-1600
HDM31250CD1A2	Motor Mechanism AC230V HDM3-1600
HDM31250CD1A3	Motor Mechanism AC400V HDM3-1600
HDM31600MNA2	Undervoltage release (Left/Wire) AC230V HDM3-1600
HDDM31600MNA3	Undervoltage release (Left/Wire) AC400V HDM3-1600
HDDM31600MX1A2L	Shunt Release (Left/Wire) AC230V HDM3-1600
HDDM31600MX1A3L	Shunt Release (Left/Wire) AC400V HDM3-1600
HDDM31600MX1D2L	Shunt Release (Left/Wire) DC24V HDM3-1600

LOW VOLTAGE DISTRIBUTION

HDM3-1600 MCCB



Technical Parameters-@40°products

MCCB		HDM3-1600
[Ue] rated operational voltage 50/60Hz		400/415
[Ui] rated insulation voltage		1000
[Uimp] rated impulse withstand voltage		12
[In]Current (A)		800/1000/1250/1600
Pole		3
Breaking Capacity		N
Icu(KA)	AC 400/415V	70
Ics(KA)	AC 400/415V	50
Mechanical Life		5000
Electrical Life	AC 415V	2500
Trip units	line protection	■
	Thermal & magnetic (10In)	■
connection type	Front connection	■
Accessory	Undervoltage release	■
	Shunt Release	■
	Alarm	■
	Auxiliary/Alarm	■
	Auxiliary contact	■
	Motor Mechanism	■
	Square Extended Rotation Handle)	■
Suitability for isolation		■
Utilisation category		A
Certification		TUV-CB

HDM3-1600 MCCB



Dimensions and connection HDM3 1600

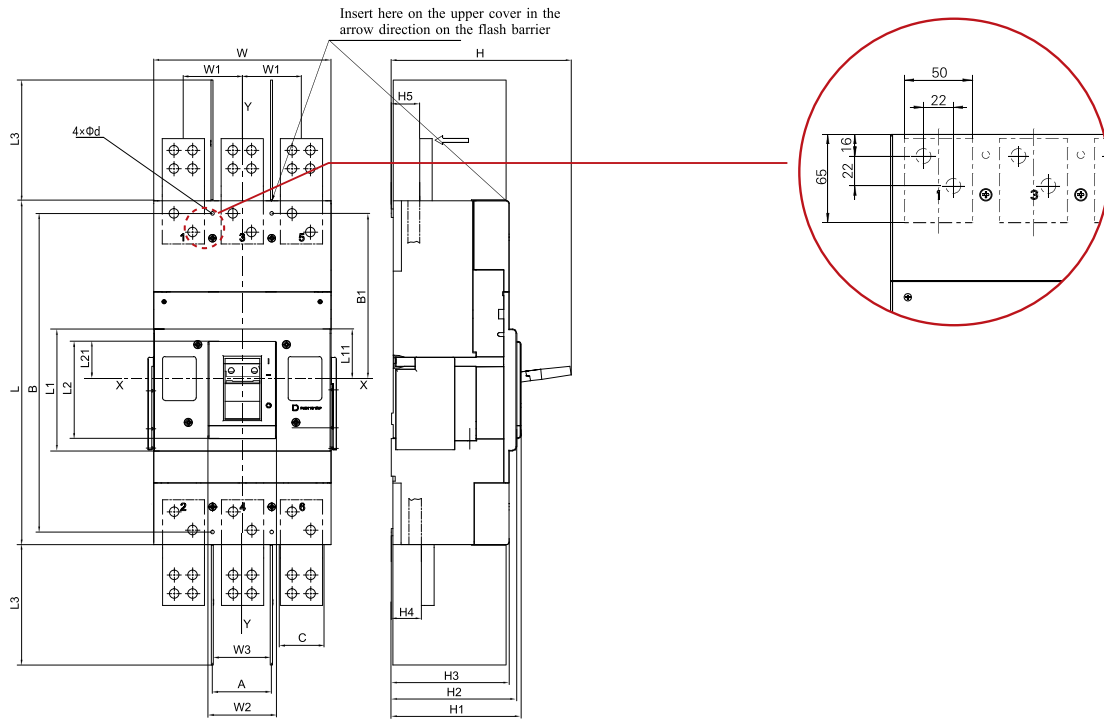

Unit:mm

Product model HDM3-	Number of poles	Outline dimensions															Installation dimensions					
		L	L1	L11	L2	L21	L3	W	W1	W2	W3	H	H1	H2	H3	H4	H5	A	B	B1	C	Φd
1600F/N	3	408	145	52	115	37	140	223	70	81	68	213	154	149	140	36	34	70	378	189	50	6

Recommended value for the wiring capacity

Rated current(A)	700 800	1000	1250	1600
Recommended sectional area of wire(mm ²)	240x2	-	-	-
Recommended sectional area of copper busbar(mm ²)	250x2	300x2	400x2	500x2

Recommended value of the wiring screw tightening torque

Product model HDM3-	1600
Socket hex wiring screw	M10
Torque(N.m)	11-14

LOW VOLTAGE DISTRIBUTION

HDM3-1600 MCCB

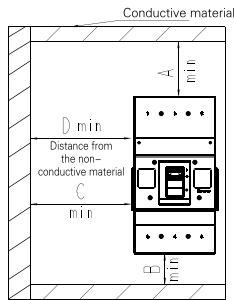

Safety Distance

Product model HDM3-	Amin	Bmin	Cmin	Dmin
1600F/N	110	55	10	0

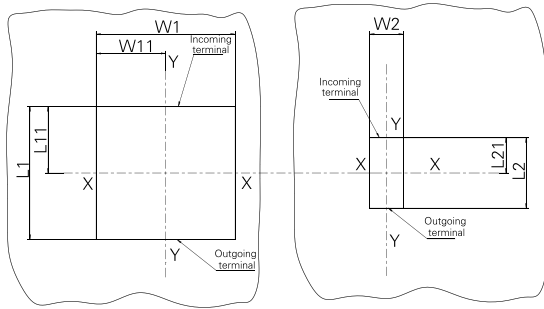

Hole dimensions of fixed and inserted panels (mm)

Product model HDM3-	Number of poles	1600 Exposed front cover and toggle handle				Exposed toggle handle		
		L1	L11	W11	W1	L2	L21	W2
1600/F	3P	148	53.5	106.5	213	118	38.4	84

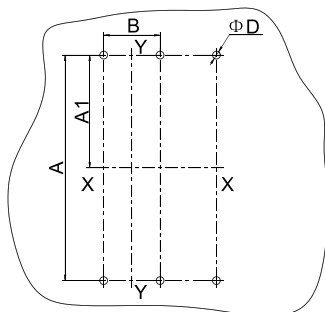

Size of the hole on the mounting plate

Product model HDM3-	Number of poles	A	A1	B	Φd
1600/F	3P	378	189	70	6.2

Internal accessories and expansion functions

Internal accessories(undervoltage release, shunt release, assists, alarm, dualassist, and auxiliary alarm)

- Assembly diagram

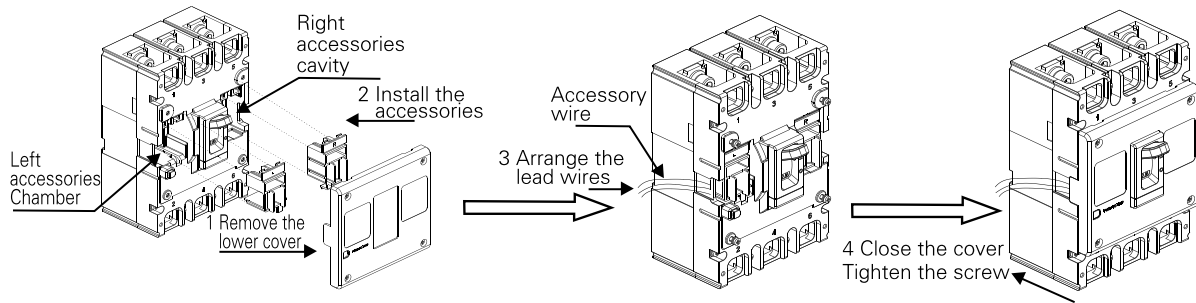

- Installable accessories in each cavity

Left accessory cavity for: left shunt, and left undervoltage

Right accessory cavity for: right single assist, right dual assist, right alarm, and right auxiliary alarm

- Wiring and schematic diagram

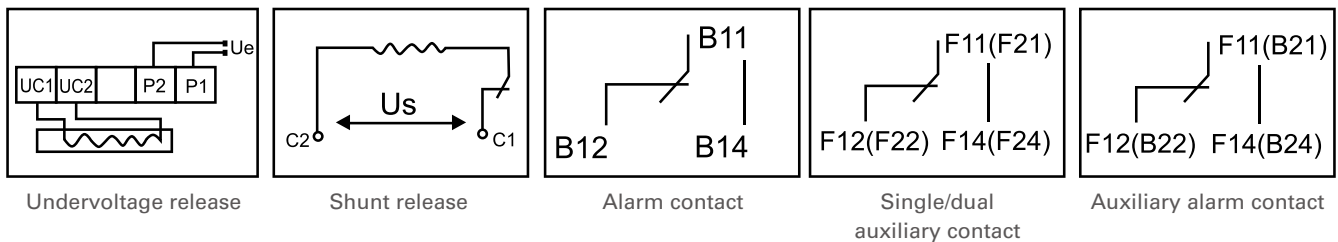

- Electrical parameters

Product model HDM3- 1600F/N	Undervoltage coil holding power consumption(W)		Min. power for suction of undervoltage coil(W)	
	AC400V	AC230V	AC400V	AC230V
	1.12	1.08	Auxiliary suction type	Auxiliary suction type

Product model HDM3- 1600	Installation position AC400V Left cavity-	Min. power for suction of undervoltage coil(W)		
		AC400V	AC230V	DC24
		175	130	80

Alarm and assist electrical parameters			
Resistive current		3A	
Use category(GB/T 14048.5-1)		AC15	DC13
Working voltage 50/60Hz	AC400V	0.3A	-
	DC220V	-	0.15A

• Test requirements for internal accessories

- Undervoltage release
 - When the rated working voltage is ranged 35% to 70%, the undervoltage release will work to trip the circuit breaker;
 - When the rated working voltage is ranged 85% to 110%, the undervoltage release can work to allow the circuit breaker can be closed reliably;
 - When the rated working voltage is below 35%, the undervoltage release can work to prevent the circuit breaker from being closed;
- When 70%~110% rated voltage is applied onto the shunt release, the circuitbreaker can be open reliably, and the handle is turned to the Trip position;
- For circuit breaker with an auxiliary contact, when the circuit breaker is open or closed, the conversion signal of the auxiliary contact shall be issued normally;
- For circuit breaker with an alarm contact, when the circuit breaker is closed or trips (press the red trip button), the conversion signal of the alarm contact shall be issued normally.

⚠ Attention

When the rated power voltage of the shunt release is DC24V, the maximum length of the copper wire cannot exceed the value listed in the table below.

Rated control power voltage U_s (DC24V)	Sectional area is 1.5mm ²	Sectional area is 2.5mm ²
100% U_s	150m	250m
80% U_s	100m	160m

If the requirements of the above table cannot be met, it is recommended to use the following figure for the design of the control circuit of the shunt release:

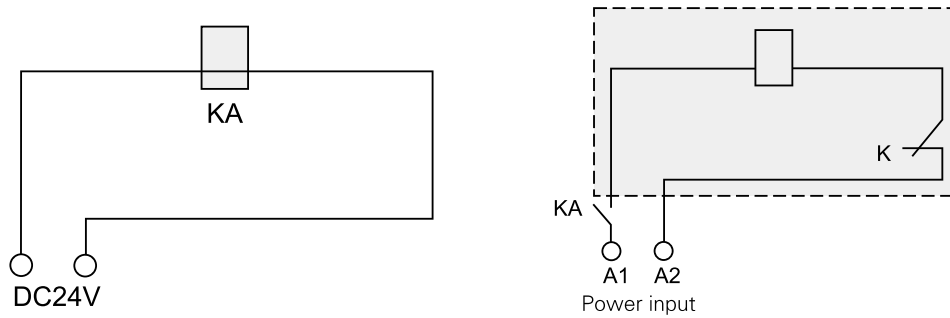

External Accessories

Manual operating mechanism

- Optional handle style and size

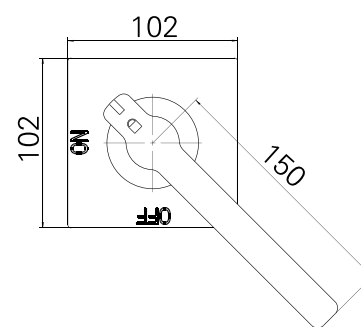
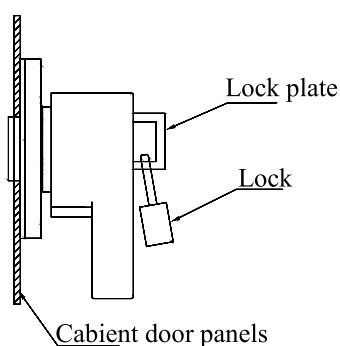
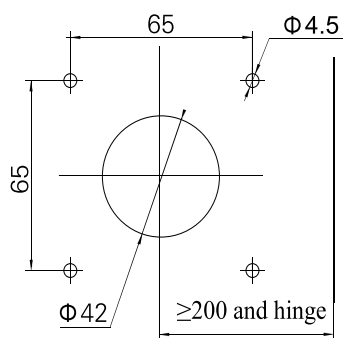

Dimensions of the mounting hole for handle cabinet door

- Features of the operating handle:

When the circuit breaker is at the Closed state, the cabinet door cannot be opened;

When at the Closed or Open state, pull the lock plate marked with on the square operating handle for locking (lock with a diameter ranged 5 to 8mm self-provided by the user).

- Outline dimensions of manual operating mechanism

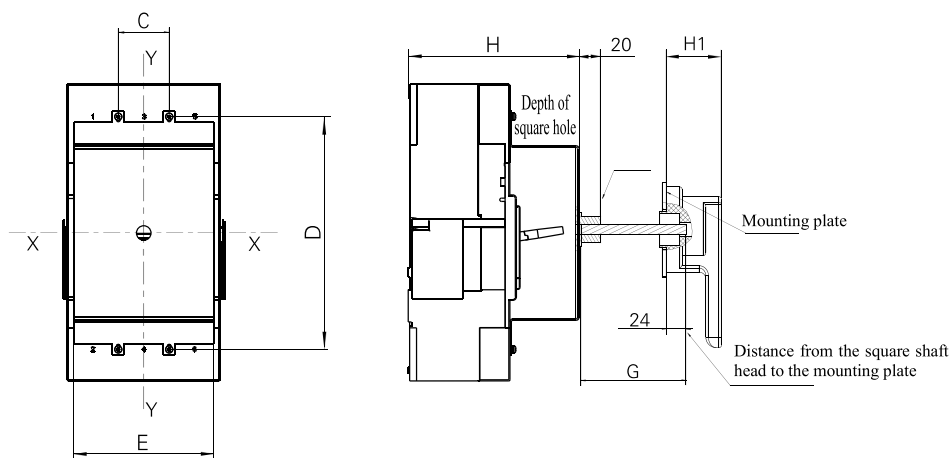

Model HDM3-	A*	C	D	E	H	G*direct manual operating mechanism	G* extended manual operating mechanism (by default)	Height of round handle H1
1600F/N	-	70	320	193	236	40	150	91

Attention

G* For other length to be customized, please contact the manufacturer.

HDM3-1600 MCCB



- Manual operating mechanism installation method

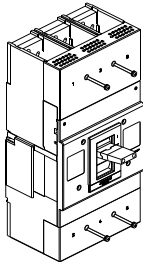

Step 1
Remove four screws from the cover of circuit breaker

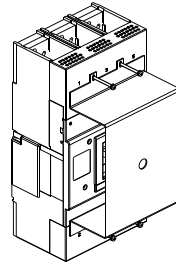

Step 2
Insert the handle of the circuit breaker into the manual operating mechanism, and tighten the screw; Insert the square shaft, and tighten the screw with a screwdriver; assemble the handle and check whether the product can be closed and opened normally.

Electric operating mechanism

- Electric operating mechanism installation dimensions

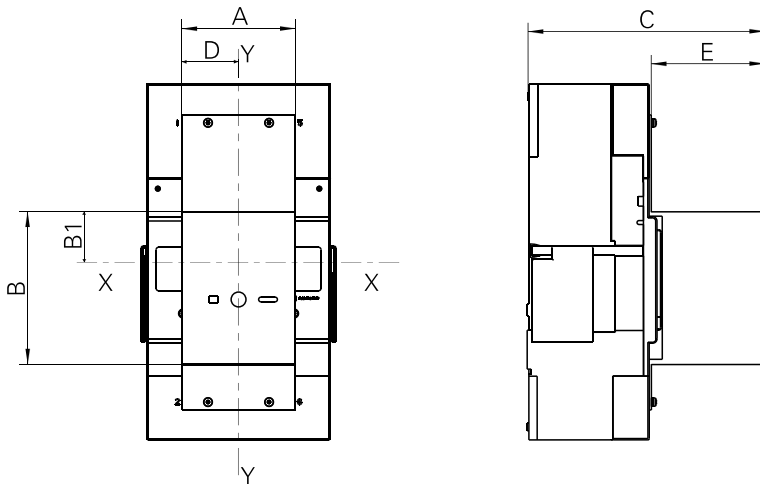

Model HDM3-	A	B	B1	C	D	E
1600F/N	131	177	63	281	65.5	141

- Installation method

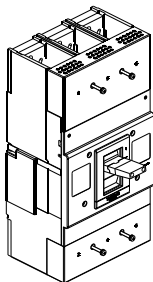

Step 1
Turn the handle to the Open position

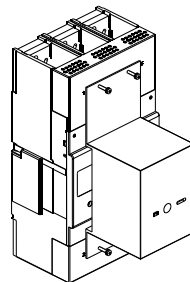

Step 2
Install the electric operating mechanism, and tighten the screw and nut

⚠ Attention

Check whether the handle can be inserted into the electric operating mechanism before operation.

LOW VOLTAGE DISTRIBUTION

HDM3-1600 MCCB



Electric operating mechanism wiring diagram

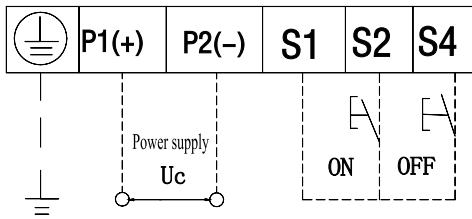

Figure: 1. P1 and P2 are connected to the power wire;
2.S1 is the common terminal; closed if S1 and S2 are powered on, and opened if S1 and S4 are powered on.

⚠ Attention

1. When the circuit breaker of the electric operating mechanism trips, the electric operating mechanism must be opened firmly and then closed;
2. At the manual operation mode, turn it clockwise 180° rather than counter clockwise operation.
3. Voltage withstand test: The 50HZ,1890V power frequency voltage can be withstood between the incoming terminals P1 and P2(not including S1,S2 and S4) of the power supply and the electric operating mechanism mounting screw.
- 4 For electric operating mechanism, P1 and P2 cannot be connected to the S1, S2, and S4.

Technical Parameters of Electric Operating Mechanism

Model of electric operating mechanism	Action current(A)	Motor power(W)
	230VAC / 400VAC	
1600	≤2	35

* Rated control power voltage: When AC 230V, the allowable voltage tolerance is ranged AC184~253V.

* Rated control power voltage: At AC 400V, the allowable voltage tolerance is ranged 320 to 440V.

Trip curve HDM3 1600

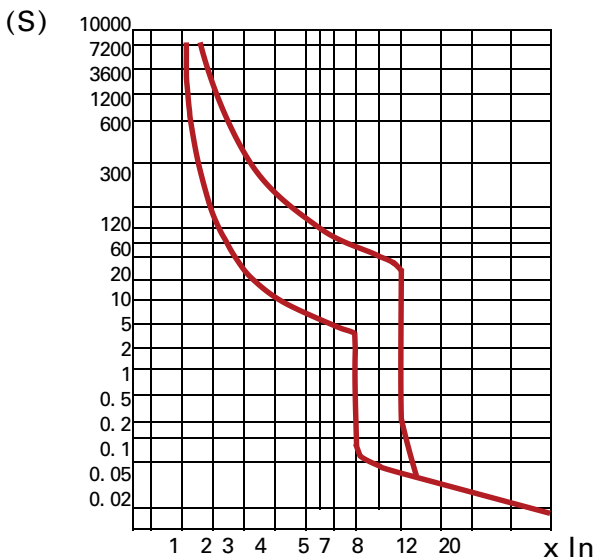

HDM3S MCCB ⚠



Range Presentation

HDM3S is Himel 3 series range of Molded Case Circuit Breakers with adjustable thermal magnetic trip unit, providing line protection, up to 630A.

Features

- ◆ Double-deck cover design assures easy installation and removal of accessories.
- ◆ Thermal adjustable range (0.8~1)I_n ,magnetic adjustable range (5~10)I_n
- ◆ All series Ics=100%Icu.

Online Content



HDM3S

MCCB Selection Code

Range name	Frame Size	Breaking capacity	Rated current	Poles	Protection	Temperature
HDM3S	160	M	160	3	3XX	
HDM3S	160: 160A 250: 250A	M: 35/35kA	025: 25A 032: 32A ...	3: 3P B: 4P*	3XX: Thermal-magnetic adjustable 2XX: Magnetic protection, Magnetic adjustable only 1XX: Thermal-magnetic protection, Thermal adjustable only	Default: 40°C T: 50°C
	400: 400A 630: 630A	M: 50/50kA	500: 500A 630: 630A			

- Note: 1. B: The N phase is equipped with contacts, but without protection. It closes earlier and opens later than the other 3 poles.
 2. If 2xx, 1xx products required, please contact local Himel sales.
 3. Thermal -magnetic adjustable (3XX) , the minimum I_n=63A
 4. "T" is thermal trip calibrated in 50 degree. For further requirement, please contact local sales.

Frame Size(A)	Rated Current (A) @40°C I _n																
	25	32	40	50	63	80	100	125	140	160	200	250	320	400	500	630	
160	█																
250									█								
400											█						
630														█			

Technical Parameters				
Frame	HDM3S-160	HDM3S-250	HDM3S-400	HDM3S-630
Standard	IEC 60947-2	IEC 60947-2	IEC 60947-2	IEC 60947-2
[U _{imp}] rated impulse withstand voltage	8kV	8kV	8kV	8kV
[U _i] rated insulation voltage	AC1000V	AC1000V	AC1000V	AC1000V
Network frequency	50/60 Hz	50/60 Hz	50/60 Hz	50/60 Hz
[U _e] rated operational voltage	400/415VAC	400/415VAC	400/415VAC	400/415VAC
Poles	3/4	3/4	3/4	3/4
Suitability for isolation	Yes	Yes	Yes	Yes
Utilisation category	Category A		Category A	Category A
[I _n]Current	25/32/40/50	63/80/100/125/160	140/160/200/250	250/320/400
Thermal Adjustable	0.8,0.9,1.0	0.8,0.9,1.0	0.8,0.9,1.0	0.8,0.9,1.0
Magnetic Adjustable	/	5,6,7,8,9,10	5,6,7,8,9,10	5,6,7,8,9,10
Breaking Capacity	M	M	M	M
400VAC Icu	35	35	50	50
400VAC Ics	35	35	50	50
Mechanical Life	8500	7000	4000	4000
Electrical Life	1500	1000	1000	1000
Dimension (WxHxD)	90-155-108(3P)/ 120-155-108(4P)	105-165-116(3P)/ 140-165-116(4P)	140-257-155(3P)/ 184-257-155(4P)	140-257-155(3P)/ 184-257-155(4P)
Ambient air temperature for operation	40/50 °C	40/50 °C	40/50 °C	40/50 °C
Certificates	TUV/ CB	TUV/ CB	TUV/ CB	TUV/ CB

LOW VOLTAGE DISTRIBUTION

HDM3S MCCB



Operating Conditions

Pollution degree

HDM3S products operate in the environment (industrial environment) with pollution class 3 defined in IEC/EN 60947-1 and IEC/EN 60947-2 standards.

Environment temperature

- HDM3S series can work for a long time under normal environment and operating temperature between -5°C and 50°C.
- Refer to the temperature derating factor table or contact us if the operating ambient temperature exceeds 40°C
- Storage temperature ranges between -20°C and 70°C.

Altitude

- Altitude at normal installation site does not exceed 2000m.
- If the altitude exceeds 2000m, the changes in the dielectric strength and the air temperature drop must be considered. Refer to the altitude derating factor table or contact us.

Humidity

The following conditions must be met during normal operation:

- The relative humidity of atmosphere does not exceed 50% if the ambient air temperature is +40°C. The product can be used at a high relative humidity if the temperature is low.
- The monthly average relative humidity at the wettest month is 90%.
- The impact of the condensation generated on the product surface on the product property shall be considered.

Protection class

- IP protection class of circuit breaker body: IP20
- Circuit breaker installed in the switch cabinet: circuit breaker with a toggle handle IP40
circuit breaker with an electric operating mechanism IP40

Safety Distance

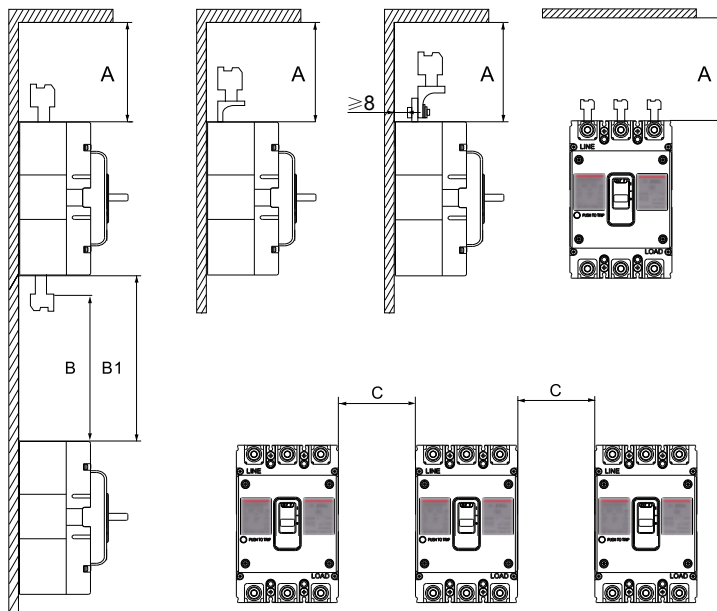

Model	A	B	C(mm)
HDM3S-160	60	60	30
HDM3S-250	60	60	30
HDM3S-400	110	110	70
HDM3S-630	110	110	70



This offer is available only in Middle East / North African countries.
For more information, contact local Himel Sales.





HDM3S MCCB





Molded Case Circuit Breakers HDM3s Series



APPLICATIONS

-  Utility
-  Building and Residential
-  Industrial
-  Panel Building

FEATURES

-  Double-deck cover design
-  $I_{ca} = I_{cu}$
-  Wide Thermal and Magnetic Adjustable Ranges

LOW VOLTAGE DISTRIBUTION

HDM3S MCCB



Installation Position

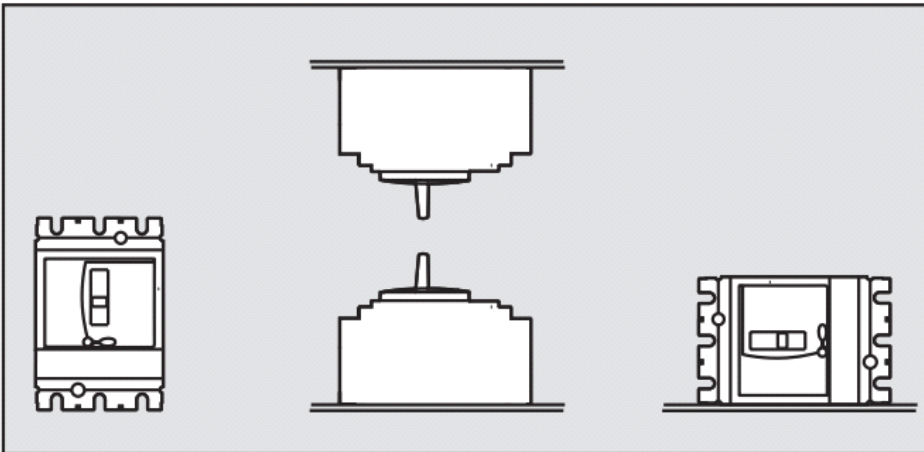

Derating

Product type	Ambient temperature (40°C product)				
	40	45	50	55	60
HDM3S-160	1	0.96	0.89	0.83	0.75
HDM3S-250	1	0.92	0.85	0.79	0.71
HDM3S-400/630	1	0.94	0.87	0.81	0.73

Note: For 50°C product temperature derating, please confirm with local Himel sales office.

	Altitude			
	2000m	3000m	4000m	5000m
Insulation voltage U_i (V)	800	728	664	616
U_{imp} (kV)	8	7	6.5	6
Power frequency withstand voltage (V)	3000	2500	2100	1800
Rated heat value at 40°C (A) $*I_n$	1	0.94	0.88	0.85

Power loss of three poles(W)

Product type	Rated current	Front connection	Rear connection	Plug-in connection	Withdrawable connection
HDM3S-160	160	60	87	87	-
HDM3S-250	250	63	90	90	-
HDM3S-400	400	115	120	120	128
HDM3S-630	630	180	190	190	205

HDM3S MCCB



Trip Units

Thermal and magnetic

Protection

The circuit breaker equipped with TM thermomagnetic release is mainly for protection of the cable, which is on the power distribution system for transformer power supply.

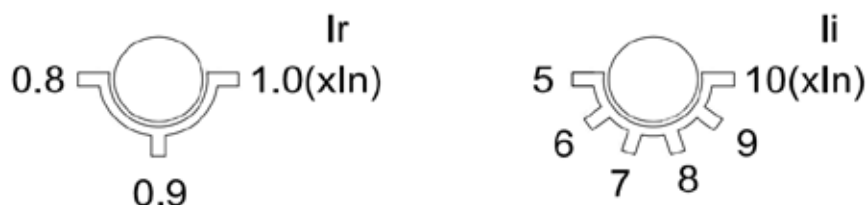

Overload protection: thermal protection Ir (Adjustable)

The overload protection function provides inverse time limit curve on the basis of bimetal. If the limit is exceeded, the deformation of the bimetal can lead in the tripping of the circuit breaker operating mechanism.

Thermal adjustable range: 0.8, 0.9, 1.0In

Test No.	I/In	Conventional time	Breaker status	Initial status
1	1.05	> 1h(In ≤ 63A) > 2h(In > 63A)	Non-tripping	Cold status
2	1.3	≤ 1h(In ≤ 63A) ≤ 2h(In > 63A)	Tripping	Immediately after test 1

Note: For 160A breaker, rated current is under 50A, only have thermal adjustable breaker.

Short circuit protection: magnetic protection Ii (Adjustable)

Magnetic protection achieves short circuit protection through a magnetic trip device. The circuit breaker will trip instantaneously.

Magnetic adjustable range: 5, 6, 7, 8, 9, 10In

Test No.	I	Breaker status	Conventional time
1	80%Ii	Non-tripping	≥0.2s
2	120%Ii	Tripping	≤0.2s

HDM3S MCCB



Accessories

Overview of Accessories

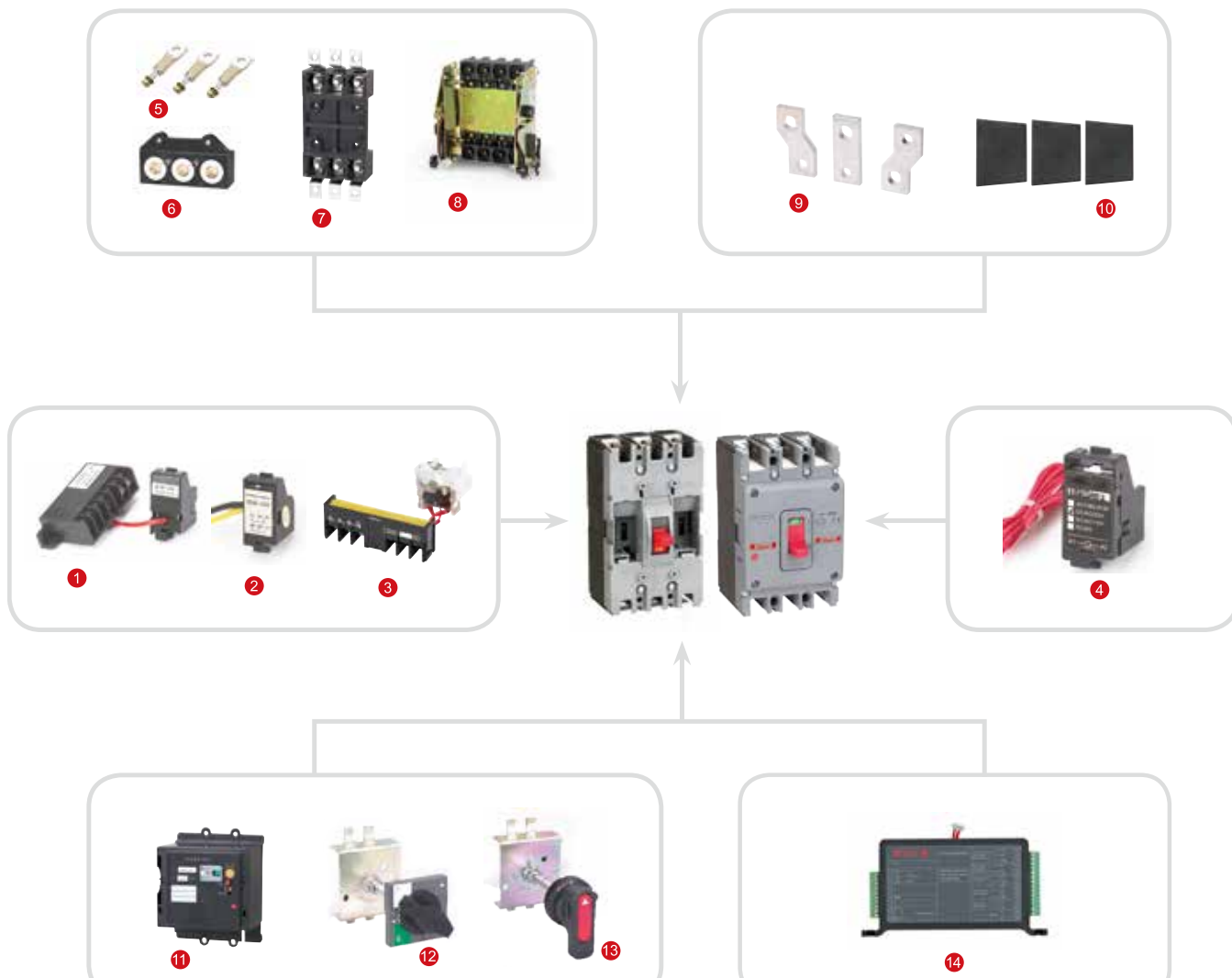

1	Undervoltage release	7	Plug-in front connection	13	Round handle operating mechanism
2	Auxiliary contact	8	Withdrawable connection	14	Hand lock
3	Alarm contact	9	Extension terminal	15	Terminal cover
4	Shunt release	10	Interphase barriers	16	Cage lug
5	Fixed rear connection	11	Electric operating mechanism		
6	Plug-in rear connection	12	Square handle operating mechanism		

Note:

For more information about the accessories, please go to Himel website and download MCCB catalogue.

HDM3S MCCB



Internal Accessories

Auxiliary contact

An accessory connected in the auxiliary circuit of the switching device to indicate the circuit breaker status of ON or not.

Electrical wiring diagram

Accessory name	ON	OFF/TRIP
Auxiliary		

Electrical parameters

Conventional Thermal Current	3A		
Use category		AC 15	DC 13
Working electricity 50Hz	AC 400V	0.3A	
	DC 220V		0.15A

Alarm contact

An accessory used to indicate the circuit breaker status of ON or not. When the alarm contact indicates that the circuit breaker is at Trip status, there are the following five possibilities.

- Overload or short circuit fault.
- Residual current fault.
- Shunt release action.
- Line fault and undervoltage release action.

Electrical wiring diagram

Accessory name	ON/OFF	TRIP
Alarm		

Electrical parameters

Conventional Thermal Current	3A		
Use category		AC 15	DC 13
Working electricity 50Hz	AC 400V	0.3A	
	DC 220V		0.15A

Undervoltage release

- The undervoltage release shall reliably trip the circuit breaker at the voltage between 35% and 70% of the rated operational voltage;
- The undervoltage release shall ensure that the circuit breaker can be switched on at the voltage between 85% and 110% of the rated operational voltage;
- The undervoltage release shall prevent the circuit breaker from switching on when voltage is below 35% of the rated operational voltage.

Electric wiring diagram of undervoltage release

Wiring diagram

Note: X- terminal block

Note: In the dashed box,

it is the wiring diagram of accessories in the circuitbreaker.

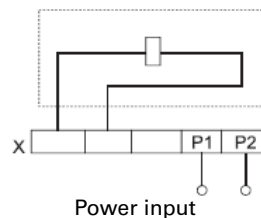

Electrical parameters

Electrical parameters	Undervoltage release power loss(W)	
	AC400V	AC230V
HDM3S-160	3.9	3.2
HDM3S-250	4.3	3.3
HDM3S-400/630	3.6	2.5



HDM3S MCCB



Internal Accessories

Shunt release

>The shunt release shall reliably trip the circuit breaker at the voltage between 70% and 110% of the rated control power voltage U

>The circuit breaker shall be reset on the site after tripping through the shunt release.

Electrical wiring diagram

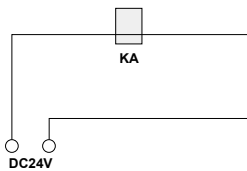

KA: DC24V intermediate relay with the contact current capacity of 1A

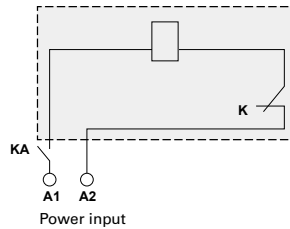

Electrical parameters

Product type	Shunt release power loss(W)		
	AC400V	AC230V	DC24V
HDM3S-160	96.8	73	91.2
HDM3S-250	112	68.6	85.3
HDM3S-400/630	67	62.3	100

External Accessories

Model	Fixed front	Fixed rear	Plug-in front	Plug-in rear	Withdrawable
HDM3S-160	■	■	■	■	-
HDM3S-250	■	■	■	■	-
HDM3S-400	■	■	■	■	■
HDM3S-630	■	■	■	■	■

Plug-in

The wiring type is divided into plug-in Rear Connection and plug-in Front Connection

The plug-in connection for the products is easy for maintenance and replacement, but plug-in and plug-out cannot be done with the electricity.



Draw out

The drawer-out products can be easily maintained and replaced Visual connection and break-up.



Extended Handle

Handle operating mechanism

The circuit breaker can be operated by the rotation of the handle and the ergonomically designed rotation handle makes the operation of the circuit breaker more flexible.

2 types of rotation handle operating mechanisms:

>Direct rotation handle (round handle operating mechanism and square handle operating mechanism)

>Extended rotation handle (round extending handle operating mechanism and square extended handle operating mechanism)



User visualization information/settings:

> 3 position indications: OFF, ON and TRIP

>The circuit breaker cannot be switched on when the door is open

>The door cannot be opened when the circuit breaker is switched on

>The axial length of the extended handle can be custom made according to the distance from the back of the circuit breaker to the door.



HDM3S MCCB



Rear connection

Easy to install and connect the products in the rear connection.



Extend terminal

The extension terminal is connected to the standard terminal of the circuit breaker, in order to provide many other wiring schemes in the limited space:

- >Direct extension terminal
- >Extension terminal with inter-electrode distance



The busbar and extension terminal can be connected to the inlet or outlet terminal of the circuit breaker.

Interphase barriers

The interphase barriers can enhance the insulating performances between phase and phases . They can be installed from the product front even though the products had mounted.

Interphase barriers will be offered by standard, 3P product(4pcs), 4P product(6pcs).



Motor

- Apply to remote electric connection, disconnection and re-trip of the circuit breaker and the automation control occasions.
- Rated voltage of electric operating mechanism: AC400V;AC230V/DC220V;AC/DC110V;DC24V
- Operating voltage range of electric operating mechanism: 85%-110% U_e.



Electrical wiring diagram

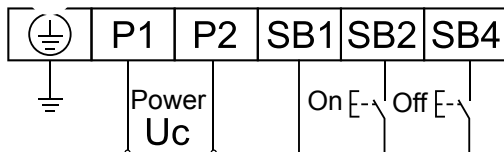

Electrical parameters

Product type	IP degree	Current	Voltage	Switch on/off time	Electric life
HDM3S160	20	≤ 1.5A	230v/380v	1S	12000
HDM3S250	20	≤ 1.5A	230v/380v	1S	12000
HDM3S400/630	20	≤ 2A	230v/380v	1S	8000



Terminal cover

Protection degree: IP40.

Protect from being contacted with main circuit.

Note: only for 3P.



Handle lock

Locking the breaker at the status of making.

Cage lug

It is used to connect with copper (aluminum) cable directly.



HDM3S MCCB



Accessories Selection Guide

Auxiliary contact with Wire

Frame Size	Auxiliary contact with Wire	
	Contact	Left
HDM3S-160	1NC+1NO	HDM3S160OF11L
	2NC+2NO	HDM3S160OF21L
HDM3S-250	1NC+1NO	HDM3S250OF11L
	2NC+2NO	HDM3S250OF21L
HDM3S-400/630	1NC+1NO	HDM3S630OF11L
	2NC+2NO	HDM3S630OF21L



Auxiliary contact with Terminal

Frame Size	Auxiliary contact with terminal	
	Contact	Left
HDM3S-160	1NC+1NO	HDM3S160OF12L
	2NC+2NO	HDM3S160OF22L
HDM3S-250	1NC+1NO	HDM3S250OF12L
	2NC+2NO	HDM3S250OF22L
HDM3S-400/630	1NC+1NO	HDM3S630OF12L
	2NC+2NO	HDM3S630OF22L



Alarm contact with Wire

Frame Size	Alarm contact Wire	
	Left	
HDM3S-160	HDM3S160AL1L	
HDM3S-250	HDM3S250AL1L	
HDM3S-400/630	HDM3S630AL1L	



Alarm contact with Terminal

Frame Size	Alarm contact terminal	
	Left	
HDM3S-160	HDM3S160AL2L	
HDM3S-250	HDM3S250AL2L	
HDM3S-400/630	HDM3S630AL2L	



Auxiliary Alarm with Wire

Frame Size	Alarm contact Wire	
	Left	
HDM3S-160	HDM3S160OFAL1L	
HDM3S-250	HDM3S250OFAL1L	
HDM3S-400/630	HDM3S630OFAL1L	



HDM3S MCCB



Auxiliary Alarm with Terminal

Frame Size	Alarm contact terminal	
	Left	
HDM3S-160	HDM3S160OFAL2L	
HDM3S-250	HDM3S250OFAL2L	
HDM3S-400/630	HDM3S630OFAL2L	



Shunt release with Wire

Frame Size	Shunt release with Wire	
	Voltage	Right
HDM3S-160	AC230V	HDM3S160MX1A2R
	AC400V	HDM3S160MX1A3R
	DC110V	HDM3S160MX1D1R
	DC220V	HDM3S160MX1D2R
	DC24V	HDM3S160MX1D3R
HDM3S-250	AC230V	HDM3S250MX1A2R
	AC400V	HDM3S250MX1A3R
	DC110V	HDM3S250MX1D1R
	DC220V	HDM3S250MX1D2R
	DC24V	HDM3S250MX1D3R
HDM3S-400/630	AC230V	HDM3S630MX1A2R
	AC400V	HDM3S630MX1A3R
	DC110V	HDM3S630MX1D1R
	DC220V	HDM3S630MX1D2R
	DC24V	HDM3S630MX1D3R



Shunt release with Terminal

Frame Size	Shunt release with Terminal	
	Voltage	Right
HDM3S-160	AC230V	HDM3S160MX2A2R
	AC400V	HDM3S160MX2A3R
	DC110V	HDM3S160MX2D1R
	DC220V	HDM3S160MX2D2R
	DC24V	HDM3S160MX2D3R
HDM3S-250	AC230V	HDM3S250MX2A2R
	AC400V	HDM3S250MX2A3R
	DC110V	HDM3S250MX2D1R
	DC220V	HDM3S250MX2D2R
	DC24V	HDM3S250MX2D3R
HDM3S-400/630	AC230V	HDM3S630MX2A2R
	AC400V	HDM3S630MX2A3R
	DC110V	HDM3S630MX2D1R
	DC220V	HDM3S630MX2D2R
	DC24V	HDM3S630MX2D3R



HDM3S MCCB



Under voltage release with Terminal

Frame Size	Under voltage release with Terminal	
	Voltage	Right
HDM3S-160	AC230V	HDM3S160MN2A2R
	AC400V	HDM3S160MN2A3R
	DC110V	HDM3S160MN2D1R
	DC220V	HDM3S160MN2D2R
	DC24V	HDM3S160MN2D3R
HDM3S-250	AC230V	HDM3S250MN2A2R
	AC400V	HDM3S250MN2A3R
	DC110V	HDM3S250MN2D1R
	DC220V	HDM3S250MN2D2R
	DC24V	HDM3S250MN2D3R
HDM3S-400/630	AC230V	HDM3S630MN2A2R
	AC400V	HDM3S630MN2A3R
	DC110V	HDM3S630MN2D1R
	DC220V	HDM3S630MN2D2R
	DC24V	HDM3S630MN2D3R



Plug-in

Frame Size	Plug-in		
	Connection type	3P	4P
HDM3S-160	Front connection	HDM3S160PF3	HDM3S160PF4
	Rear connection	HDM3S160PR3	HDM3S160PR4
HDM3S-250	Front connection	HDM3S250PF3	HDM3S250PF4
	Rear connection	HDM3S250PR3	HDM3S250PR4
HDM3S-400/630	Rear connection	HDM3S630PR3	HDM3S630PR4



Draw-out

Frame Size	Plug-in		
	Connection type	3P	4P
HDM3S-400	Horizontal connection	HDM3S400DOR3	HDM3S400DOR4
HDM3S-630	Horizontal connection	HDM3S630DOR3	HDM3S630DOR4



Motor

Frame Size	Motor				
	AC230V	AC400V	DC110V	DC220V	DC24V
HDM3S-160	HDM3S160MOA2	HDM3S160MOA3	HDM3S160MOD1	HDM3S160MOD2	HDM3S160MOD3
HDM3S-250	HDM3S250MOA2	HDM3S250MOA3	HDM3S250MOD1	HDM3S250MOD2	HDM3S250MOD3
HDM3S-400/630	HDM3S630MOA2	HDM3S630MOA3	HDM3S630MOD1	HDM3S630MOD2	HDM3S630MOD3



HDM3S MCCB



Rotation Handle

Frame Size	Rotation Handle		
	Handle shape	Direct	Extended (Default 150mm)
HDM3S-160	Round	HDM3S160H1	HDM3S160HL1
	Square	HDM3S160H2	HDM3S160HL2
HDM3S-250	Round	HDM3S250H1	HDM3S250HL1
	Square	HDM3S250H2	HDM3S250HL2
HDM3S-400/630	Round	HDM3S630H1	HDM3S630HL1
	Square	HDM3S630H2	HDM3S630HL2



Rear connection

Frame Size	Rear connection	
	3P(6pcs)	4P(8pcs)
HDM3S-160	HDM3S160RC3	HDM3S160RC4
HDM3S-250	HDM3S250RC3	HDM3S250RC4
HDM3S-400/630	HDM3S630RC3	HDM3S630RC4



Expanding terminal

Frame Size	Expanding terminal	
	3P(3pcs)	4P(4pcs)
HDM3S-160	HDM3S160C3	HDM3S160C4
HDM3S-250	HDM3S250C3	HDM3S250C4
HDM3S-400/630	HDM3S630C3	HDM3S630C4



Interphase barriers

Frame Size	Interphase barriers	
	3P(2pcs)	4P(3pcs)
HDM3S-160	HDM3S160IB3	HDM3S160IB4
HDM3S-250	HDM3S250IB3	HDM3S250IB4
HDM3S-400/630	HDM3S630IB3	HDM3S630IB4



Cage lug

Frame Size	Cage lug
	Normal(1pcs)
HDM3S-160	HDM3S160LUG
HDM3S-250	HDM3S250LUG
HDM3S-400	HDM3S400LUG
HDM3S-630	HDM3S630LUG



HDM3S MCCB



Fixed MCCB Mounting Dimension

Front connection(mm)

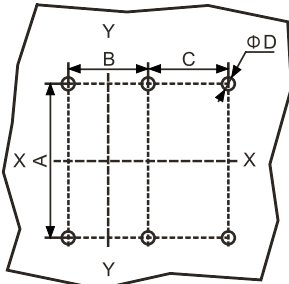

Note: X-X and Y-Y is the center of the three-pole breaker

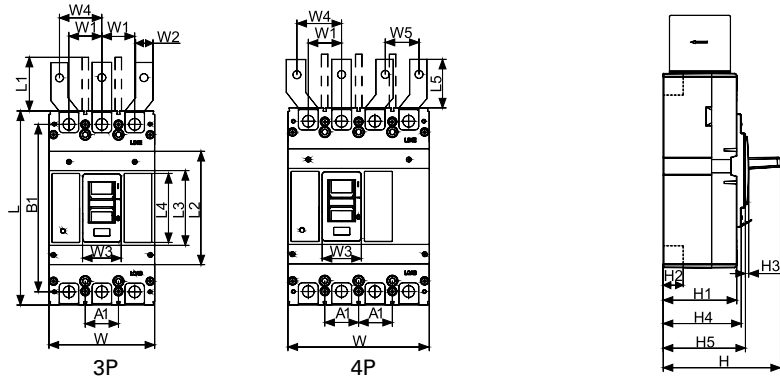

Model	Poles	Installation dimension			
		A	B	C	D
HDM3S-160	3	132	30	/	4.5
	4	132	30	30	4.5
HDM3S-250	3	126	35	/	4.5
	4	126	35	35	4.5
HDM3S-400/630	3	194	44	/	7
	4	194	44	44	7

Model	Poles	Overall dimensions																	Installation dimension		
		L	L1	L2	L3	L4	L5	W	W1	W2	W3	W4	W5	H	H1	H2	H3	H4	H5	A1	B1
HDM3S-160	3P	155	98	121	55	50	21.8	90	30	15	25.3	39	/	107	75	20	2.6	82	87	30	134
	4P	155	98	121	55	50	21.8	120	30	15	25.3	39	30	107	75	20	2.6	82	87	30	134
HDM3S-250	3P	165	98	102	59	50	41.8	105	35	20	24	42	/	116	81	23	3	88	93	35	144
	4P	165	98	102	59	50	41.8	140	35	20	24	42	35	116	81	23	3	88	93	35	144
HDM3S-400/630	3P	257	98	150	99	91	45.4	140	43.5	28	51	56	/	150	97	30	4	103	109	44	230
	4P	257	98	150	99	91	45.4	185	43.5	28	51	56	44	150	97	30	4	103	109	44	230

Rear connection(mm)

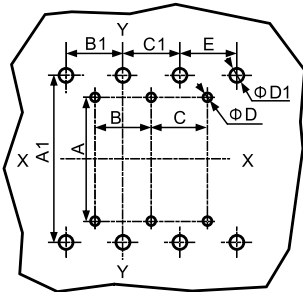

Note: X-X and Y-Y is the center of the three-pole breaker

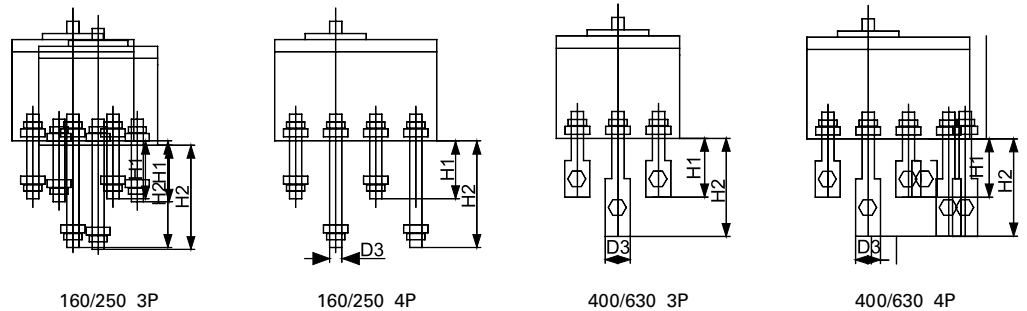

Model	Poles	Dimensions											
		A	B	C	D	A1	B1	C1	E	D1	H1	H2	D3
HDM3S-160	3	132	30	/	4.5	134	30	30	/	9.8	112	72	φ8
	4	132	30	30	4.5	134	30	30	30	9.8	112	72	φ8
HDM3S-250	3	126	35	/	4.5	144	35	35	/	8	126	87	φ8
	4	126	35	35	4.5	144	35	35	35	8	126	87	φ8
HDM3S-400	3	194	44	/	7	230	43.5	43.5	/	10.5	136	83	30
	4	194	44	44	7	230	43.5	43.5	44	10.5	136	83	30
HDM3S-630	3	194	44	/	7	230	43.5	43.5	/	10.5	136	83	32
	4	194	44	44	7	230	43.5	43.5	44	10.5	136	83	32

HDM3S MCCB



Plug-in MCCB Mounting Dimension

Front connection (mm)

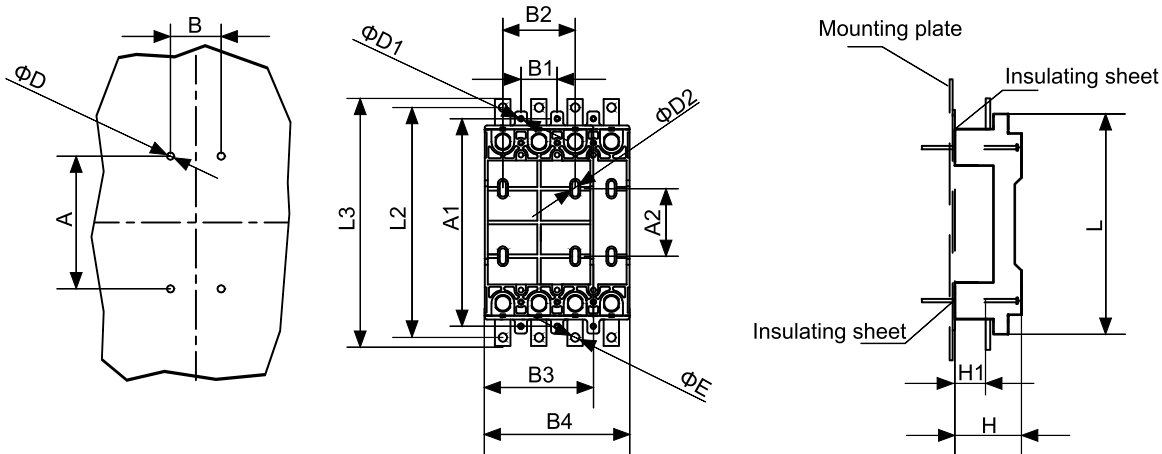

Model	Poles	Dimension																
		A	B	L2	L3	D	E	H	H1	L	A1	B1	D1	A2	B2	B3	B4	D2
HDM3S-160	3	112	30	200	216	4.5	6.5	56	28	182	172	30	5.5	67	60	90	-	6.5
	4	112	30	200	216	4.5	6.5	56	28	182	172	30	5.5	67	60	-	120	6.5
HDM3S-250	3	150	35	223	243	4.5	8.5	74	33	202	191	35	5.5	74	70	105	-	6.5
	4	150	35	223	243	4.5	8.5	74	33	202	191	35	5.5	74	70	-	140	6.5
HDM3S-400	3	249	44	332	358	5.5	10.5	85	36	310	295	44	6.5	146	88	140	-	7
	4	249	44	332	358	5.5	10.5	85	36	310	295	44	6.5	146	88	-	184	7
HDM3S-630	3	249	44	332	358	5.5	10.5	85	36	310	295	44	6.5	146	88	140	-	7
	4	249	44	332	358	5.5	10.5	85	36	310	295	44	6.5	146	88	-	184	7

Rear connection(mm)

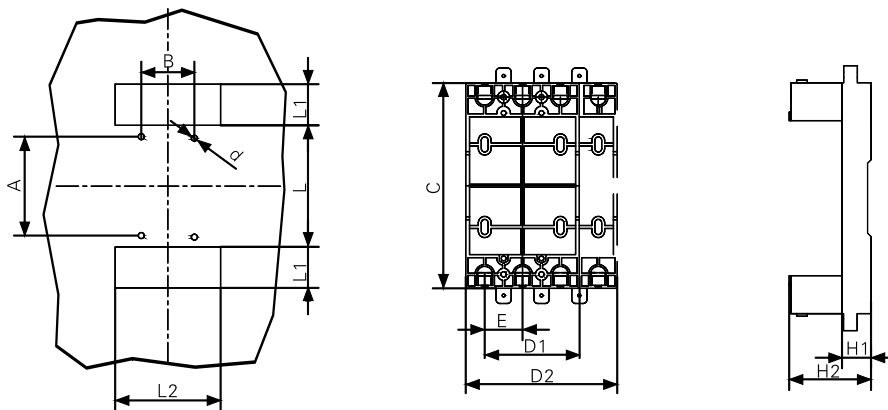

Model	Poles	Dimensions											
		A	B	L	L1	L2	d	C	D1	D2	E	H1	H2
HDM3S-160	3	67	60	90	51	94	φ6.5	162	90	-	30	20	56
	4	67	90	90	51	124	φ6.5	162	-	120	30	20	56
HDM3S-250	3	74	70	100	55	110	φ6.5	179	105	-	35	27	73
	4	74	105	100	55	145	φ6.5	179	-	140	35	27	73
HDM3S-400	3	146	88	183	70	135	φ7	279	132	-	44	45	85
	4	146	132	183	70	179	φ7	279	-	176	44	45	85
HDM3S-630	3	146	88	183	70	135	φ7	279	132	-	44	45	85
	4	146	132	183	70	179	φ7	279	-	176	44	45	85

HDM3S MCCB



Draw out Mounting Dimension

Rear connection(mm)

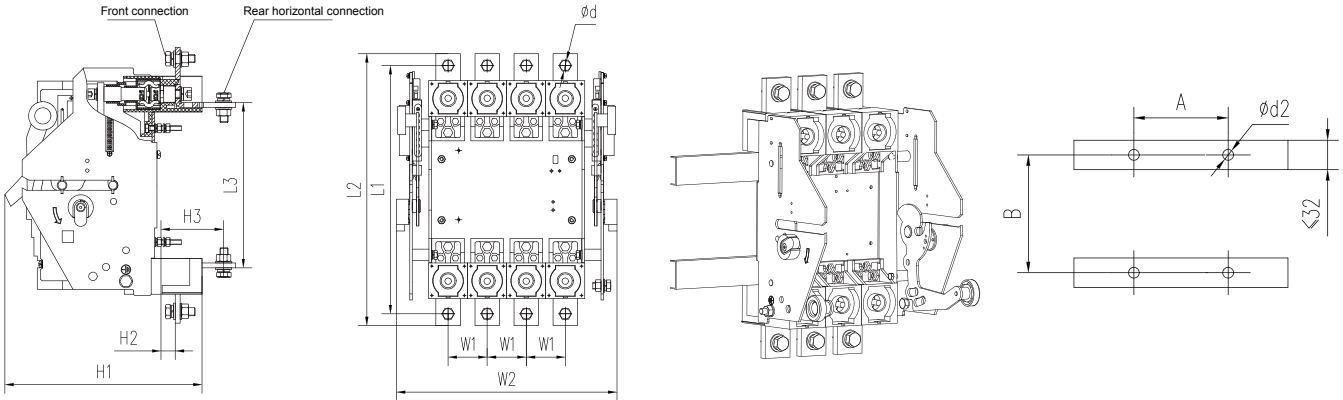

Model	Installation dimension										
	L1	L2	L3	H2	H3	W1	W2	φ D	A	B	φ c
HDM3S-400	316	345	210	25	78	44	211	11	88	146	6.5
HDM3S-630											

Rotary Handle Dimensions

Mounting with MCCB dimensions(mm)

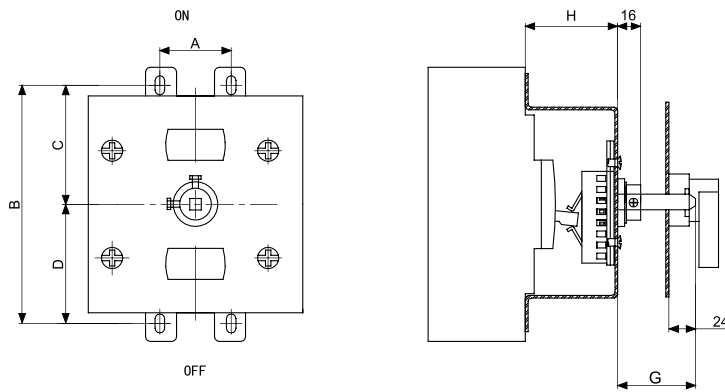

Model	A	B	C	D	H
HDM3S-160	30	132	66	66	46
HDM3S-250	35	126	63	63	51
HDM3S-400	128	194	97	97	76

Note: Default is 150mm

Handle and door cutting dimensions(mm)

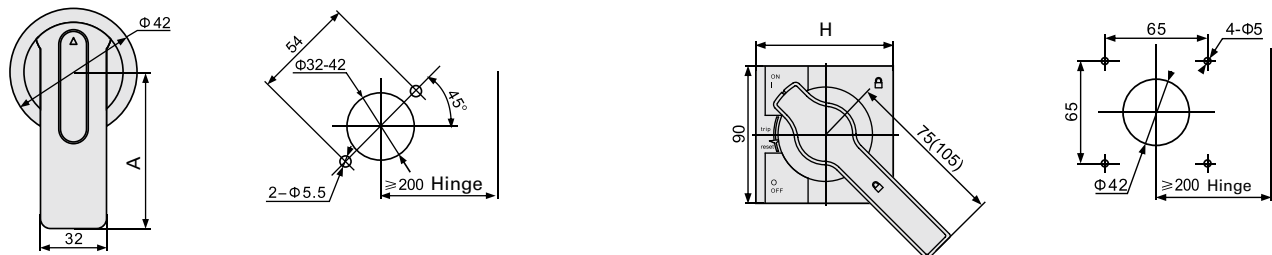

Round handle dimensions

Model	A
HDM3S-160	60/90
HDM3S-250	60/90
HDM3S-400/630	60/90

Square handle dimensions

Model	H
HDM3S-160	90
HDM3S-250	90
HDM3S-400/630	90

HDM3S MCCB



Motor Mounted with MCCB Dimensions (mm)

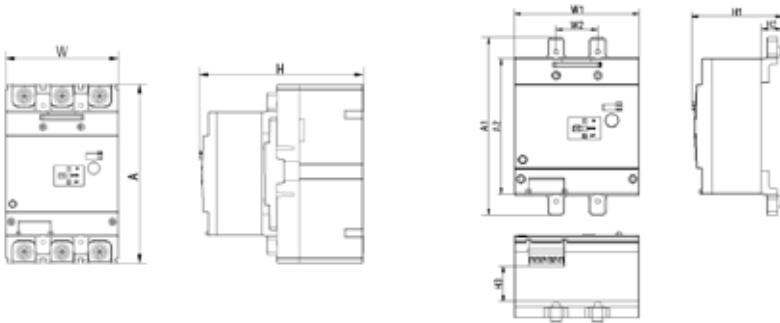

Model	A	A1	A2	W	W1	W2	H	H1	H2	H3
HDM3S-160	155	144	109.5	90	90	30	151	78.2	16.7	34.2
HDM3S-250	165	149.6	114	105	105	35	153.5	75.8	17.2	29.5
HDM3S-400	257	212	177	140	140	44	170.5	77	16.3	32.5
HDM3S-630	257	212	177	140	140	44	170.5	77	16.3	32.5
HDM3S-800	275.5	264	174	210	210	70	188.5	95	17	45

Terminal Connection Dimensions (mm)

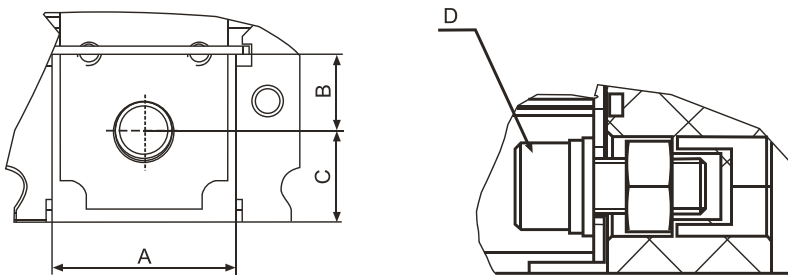

Model	A	B	C	D
HDM3-160	16	7.7	10.5	M8*20
HDM3-250	21	10	11	M8*20
HDM3-400	27.5	15.3	13.4	M10*30
HDM3-630	27.5	15.3	13.4	M10*30

Copper Conductors Size for up to 400A MCCB

Rated current A	mm ²	25	32	40 50	63	80	100	125 140	160	200	250	315	400
Cross-section of conductor	mm ²	4	6	10	16	25	35	50	70	95	120	185	240

Copper Conductors or Bars Size for above 400A MCCB

Rated current A	Quantity	Copper conductors Cross section mm ²	Copper busbar Size:mm*mm
500	2	150	30*5
630	2	185	30*5



Tripping Curves

HDM3S-160

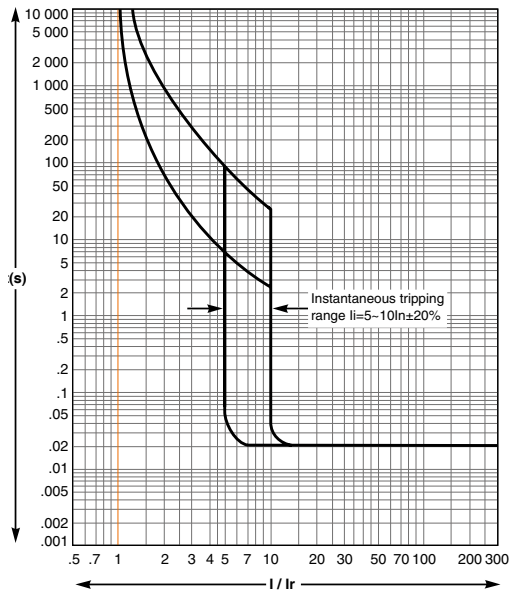

HDM3S-250

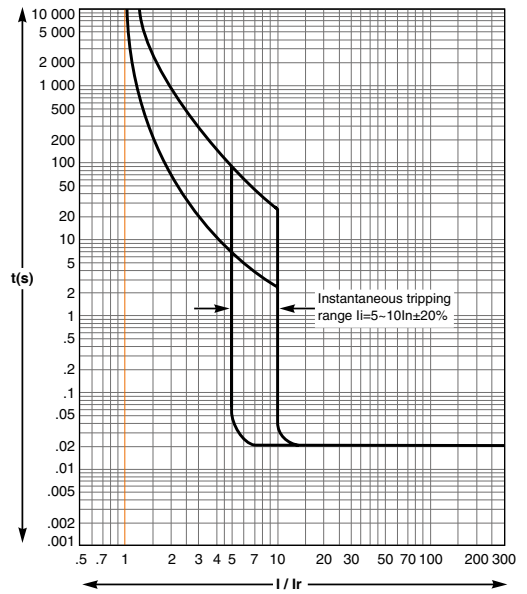

HDM3S-400

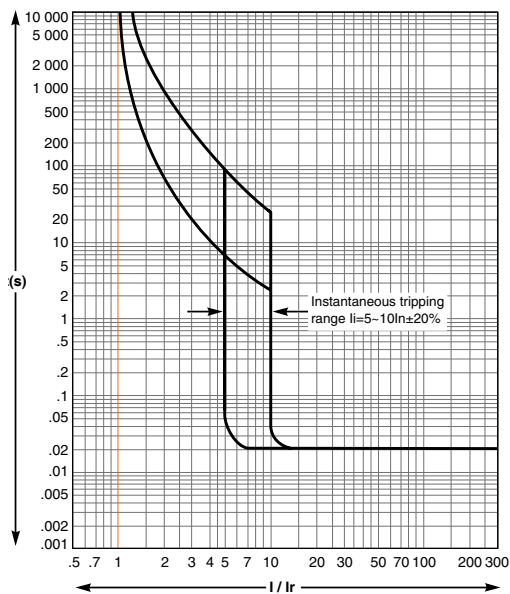

HDM3S-630

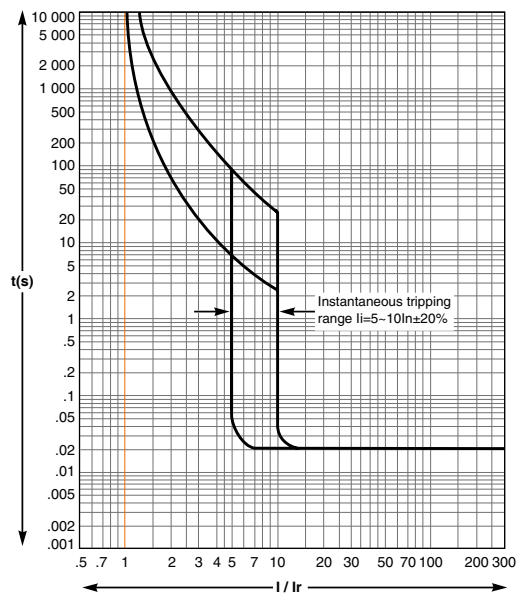



Contact us



Get in touch with Himel Team at
<https://www.himel.com/contact-us>



Find a Local Himel Distributor at
<https://www.himel.com/find-a-distributor>



Reach Himel Global Team at
support@himel.com



Contact Global Himel Marketing and Communication Team at
sm.himel.communications@himel.com



Visit Himel website at
<https://www.himel.com>
or
Scan QR Code ▼



Learn More about Himel's
15-Years of Value Engineering
Excellence
Scan QR Code ▼

